

SD Card HxC Floppy Emulator

(Rev F and Rev C)

User Manual

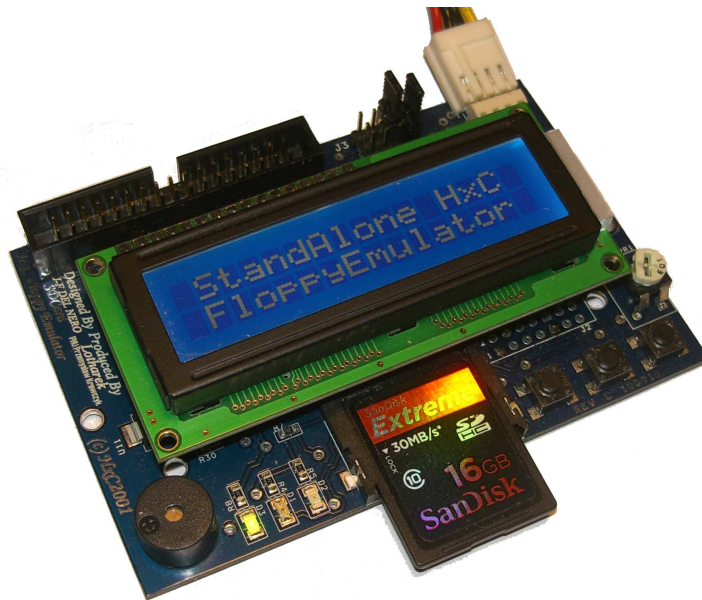

SD HxC Floppy Emulator User Guide Disclaimer

The information in this document is subject to change without notice and does not represent a commitment on the part of HxC2001. No part of this manual may be reproduced or transmitted in any form for any purpose other than the purchaser's personal use, without the express written permission of HxC2001. HxC2001 has made every effort to provide complete details about the product in this manual, but makes no warranty of any kind with regard to this material, including, but not limited to, the implied warranties of merchantability or fitness for a particular purpose. In no event shall HxC2001 be liable for any incidental, special, indirect, or consequential damages whatsoever included but not limited to lost profits arising out of errors or omissions in this manual or the information contained herein.

All trademarks mentioned in this document, belong to their respective owners.



Email :

hxc2001@hxc2001.com

©2006-2020 Jean-François DEL NERO / HxC2001 All rights reserved.

Jean-François DEL NERO
11 Rue Frédéric Magisson
75015 PARIS
France

Website : <https://hxc2001.com/>

These products are manufactured and sold by Lotharek:



LOTHAREK FHU Przemysław Krawczyk
Oświęcimska 2C /18
Świerklaniec 42-622
Polska/Poland
VAT N° PL6312246599
GIOS/WEEE N° E0016247W

Website : <https://lotharek.pl/>

© 2006-2020 Jean-François DEL NERO
© 2006-2020 HxC2001.
All rights reserved.

Summary :

1	General description / requirement	5
2	Hardware requirement / setup	6
2.1	Power supply	6
2.2	Floppy interface connection	7
2.3	Jumpers/Switches settings	8
2.3.1	Shugart / Atari ST / Amiga jumpers/switches settings	9
2.3.2	PC Compatible jumpers/switches settings	10
2.3.3	Amstrad CPC6128 jumpers/switches settings.....	11
3	Quick step by step guide	12
3.1	Install the SD HxC Floppy Emulator	12
3.2	Prepare the SD Card	12
3.3	Convert/Copy floppy images to the SD Card.....	14
3.4	Use the SD Card with the SD HxC Floppy Emulator	16
3.5	Internal settings menu	17
4	HxC Floppy Emulator software	18
4.1	Main window.....	18
4.2	SD HxC Floppy Emulator settings window	19
4.3	Custom raw file image loader / floppy generator.....	20
4.4	Floppy disk dump feature.....	21
4.5	DOS Floppy disk browser	23
5	SD HxC Floppy Emulator file selector software	24
6	SD HxC Floppy Emulator firmware update.....	25
7	Technical details.....	26
7.1	Floppy interface.....	26
7.2	Power supply	26
7.3	User Interface	27
7.4	SD Card support	27
7.5	SD Card File-system	27
7.6	Read / Write support	28
7.7	Floppy bitrate supported.....	28
7.8	Additional features	28
7.9	Mechanical drawing	29
7.10	HxC Floppy Emulator software supported file formats	31
7.11	Machines compatibility list	35
7.12	Contact / Project page	36

Figures :

Figure 1 : SD HxC Floppy Emulator Rev F.....	5
Figure 2 : SD HxC Floppy Emulator Rev C	5
Figure 3 : Power supply connector (Rev F)	6
Figure 4 : Power supply connector (Rev C).....	6
Figure 5 : Floppy connector (Rev F)	7
Figure 6 : Floppy connector (Rev C)	7
Figure 7 : Switches settings (Rev F)	8
Figure 8 : Jumpers settings (Rev C).....	8
Figure 9 : Format the SD Card in FAT32	12
Figure 10 : Copy HXCSDFE.CFG to the SDCard.....	13
Figure 11 : Start the HxCFloppyEmulator software	14
Figure 12 : Batch converter window	14
Figure 13 : HFE files after conversion	15
Figure 14 : Browse the SD Card	16
Figure 15 : Floppy image disk loaded.....	16
Figure 16 : Drive menu	17
Figure 17 : SD Card write protect switch.....	17
Figure 18 : HxCFloppyEmulator software functions.....	18
Figure 19 : SD HxC Floppy Emulator settings window	19
Figure 20 : RAW file loader window	20
Figure 21 : Floppy dump window	21
Figure 22 : DOS floppy disk file browser window	23
Figure 23 : File image selector main page and settings menu	24
Figure 24 : Floppy connector pinout.....	26
Figure 25 : Power connector pinout	26
Figure 26 : Front panel connector pinout (Rev C only)	27
Figure 27 : Rev C Mechanical drawing	29
Figure 28 : Rev F Mechanical drawing.....	30

1 General description / requirement

The SD HxC Floppy Emulator is an universal floppy drive emulator based on SD/SDHC memory cards.

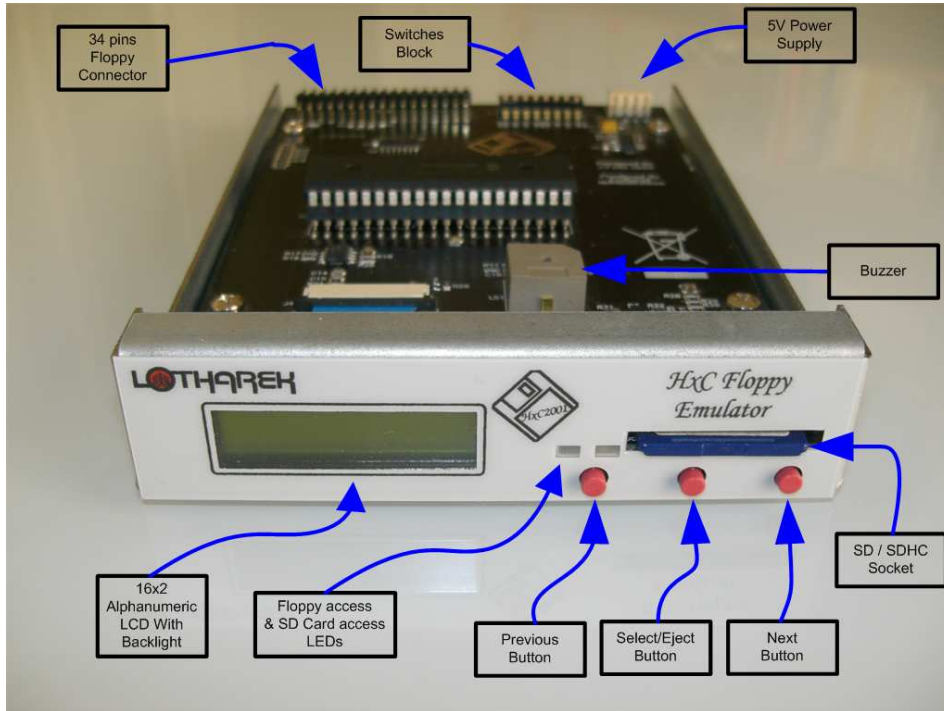

Figure 1 : SD HxC Floppy Emulator Rev F

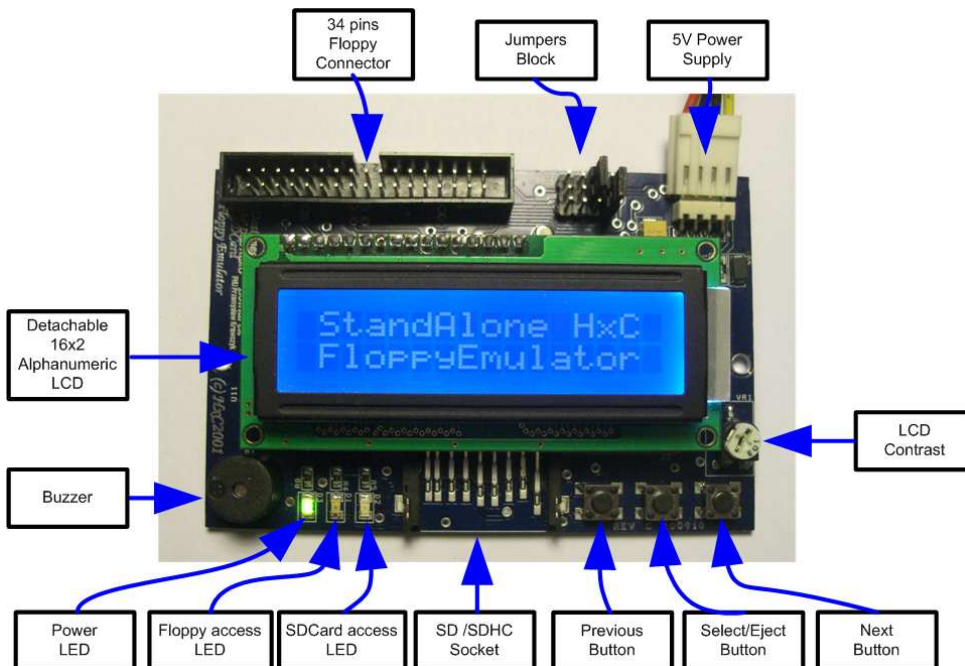

Figure 2 : SD HxC Floppy Emulator Rev C

To prepare and use it you need :

- A computer/device/sampler/keyboard with a Shugart or PC compatible floppy disk drive interface.
- An SD or SDHC memory card (from 8MB up to 32GB).
- A computer to copy floppy file images to the SD Card.

2 Hardware requirement / setup

2.1 Power supply

The SD HxC Floppy Emulator need a **+5V** power source to work. The power source must be able to deliver at least **400 mA** for proper operation (200mA for the SD HxC Floppy Emulator and 200mA for the SD/SDHC Card).

The power supply connector is a standard floppy disk drive power supply connector. The +12V line is not used by the emulator.

Below the power connector pinout :

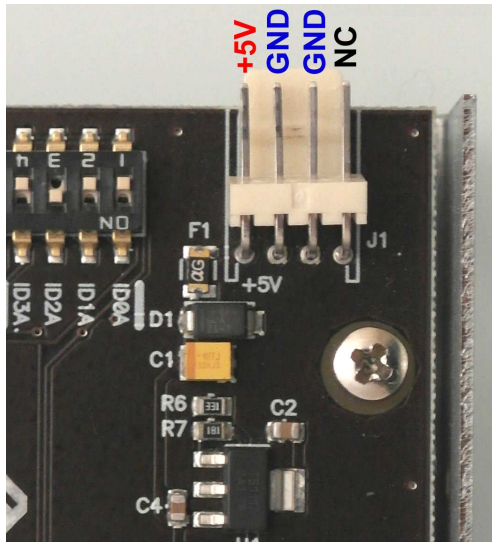



Amstrad CPC6128 users : The CPC6128 floppy connector has a reversed pinout : +5V and +12V are exchanged. Unlike others systems : Orange wire=5V, Red wire=12V, Black wires=GND. Special care must be taken before connecting the power supply connector on the CPC6128.

To test the device securely, you can disconnect the +12V power source since the CPC6128 doesn't need it.

2.2 Floppy interface connection

A 34 pin floppy ribbon must be used to connect the device to the host computer. This one can be twisted or non-twisted.

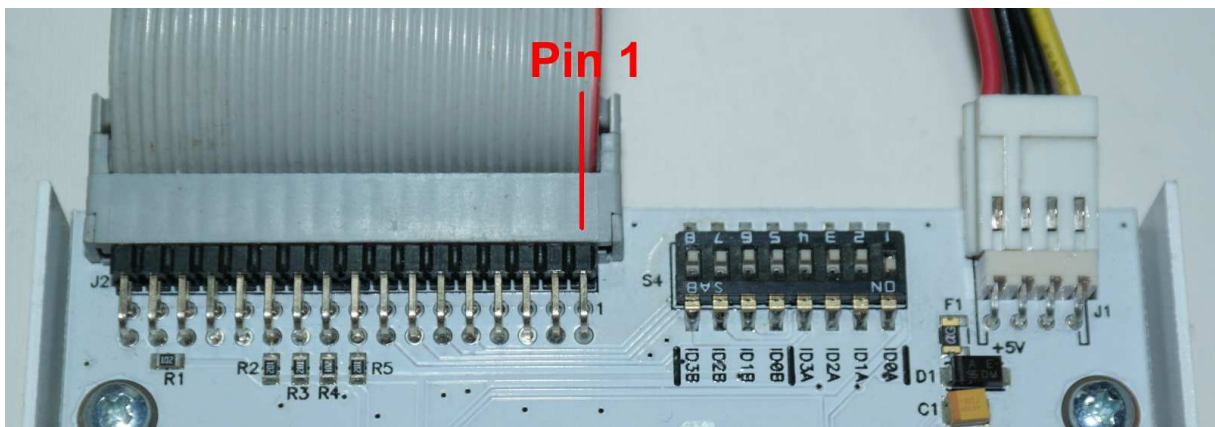

Figure 5 : Floppy connector (Rev F)

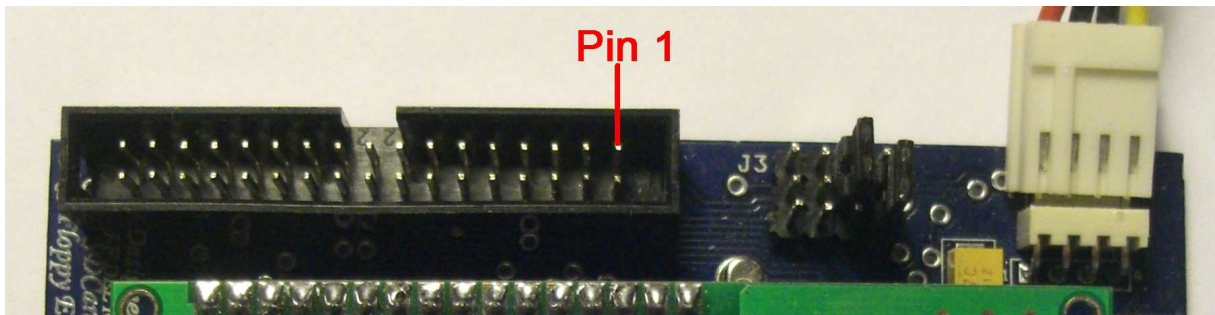

Figure 6 : Floppy connector (Rev C)

Note 1: On most machines, pin 1 are indicated by the floppy ribbon's colored wire. In this case the floppy ribbon can be connected directly (colored wire on the pin 1 side / to the right).

Note 2: On some machines (Amiga,...), the original floppy ribbon is reversed : The floppy ribbon's colored wire indicate the pin 34 ! In this case connect the floppy ribbon on the opposite side to the emulator (colored wire to the left), or reconnect the floppy ribbon in the right side on the machine motherboard. If you are using a twisted ribbon, the colored wire MUST be to the right (pin 1).

Note 3: If you are using the **Amstrad CPC6128** computer external floppy port, you must connect the floppy ribbon on the opposite side to the emulator (colored wire to the left). To turn the emulator as the first disk drive and disable the internal disk drive, the wire 23 must be connected to the ground (with the wire 24 for example).

Note 4: If the floppy access LED is permanently lit, this probably means that the floppy ribbon is connected in the wrong way. (Drive select line forced/connected to the ground).

2.3 Jumpers/Switches settings

Here is the jumpers/switches configuration settings:

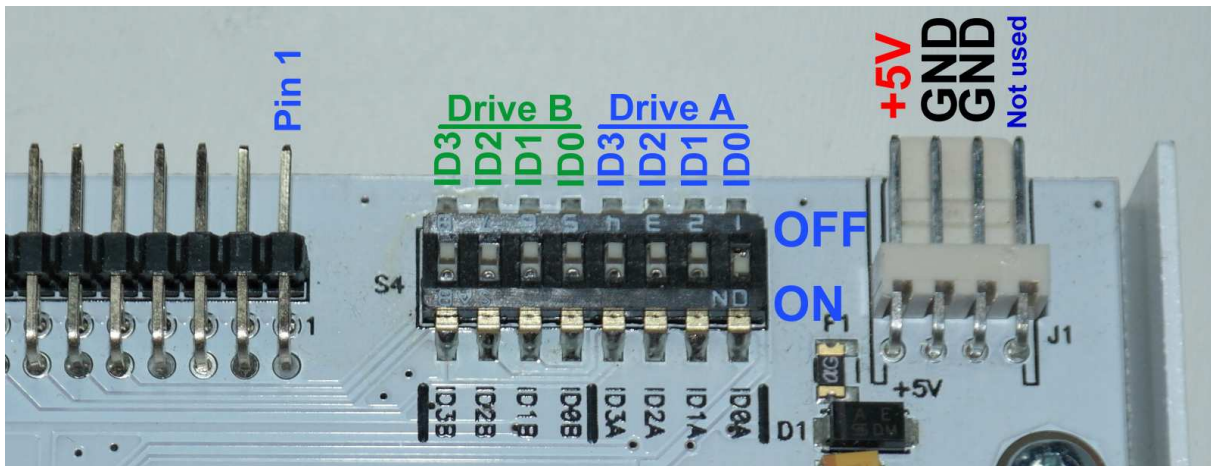

Figure 7 : Switches settings (Rev F)

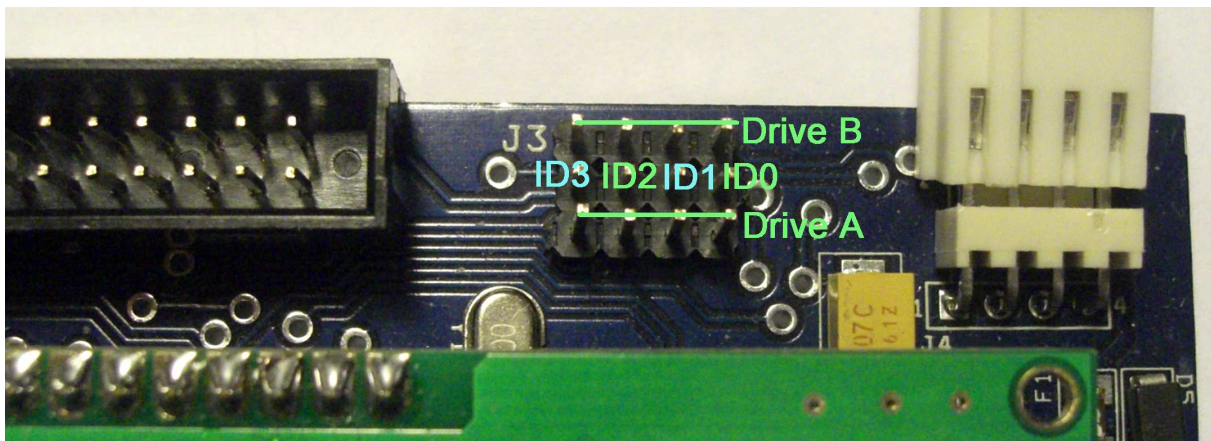

Figure 8 : Jumpers settings (Rev C)

To use the device you must assign at least one ID drive on the emulator. Since the emulator is able to emulate 2 disk drives, there are 2 ID inputs :”**Drive A**” and “**Drive B**”.

Unlike real floppy disk drive the SD HxC Floppy Emulator doesn’t use the motor control line by default. So there is only one switch/jumper to set per virtual disk drive.

The IDx/jumper/switches assignment can be different on your machine. Check the original floppy disk drive jumpers settings to compare. Below you can find some examples of settings.

2.3.1 Shugart / Atari ST / Amiga jumpers/switches settings

ID line	ID3	ID2	ID1	ID0
Host Line	MTRON	DS2	DS1	DS0
Function	Motor On	DF2	B: / DF1	A: / DF0

Table 1 : Shugart jumpers/switches setting

Note : If you are using a twisted floppy ribbon, the ID lines are reversed. In this case IDs lines assignments are reversed too:

ID line	ID3	ID2	ID1	ID0
Host Line	DS0	DS1	DS2	MTRON
Function	A: / DF0	B: / DF1	DF2	Motor On

Table 2 : Shugart jumpers/switches setting (twisted floppy ribbon)

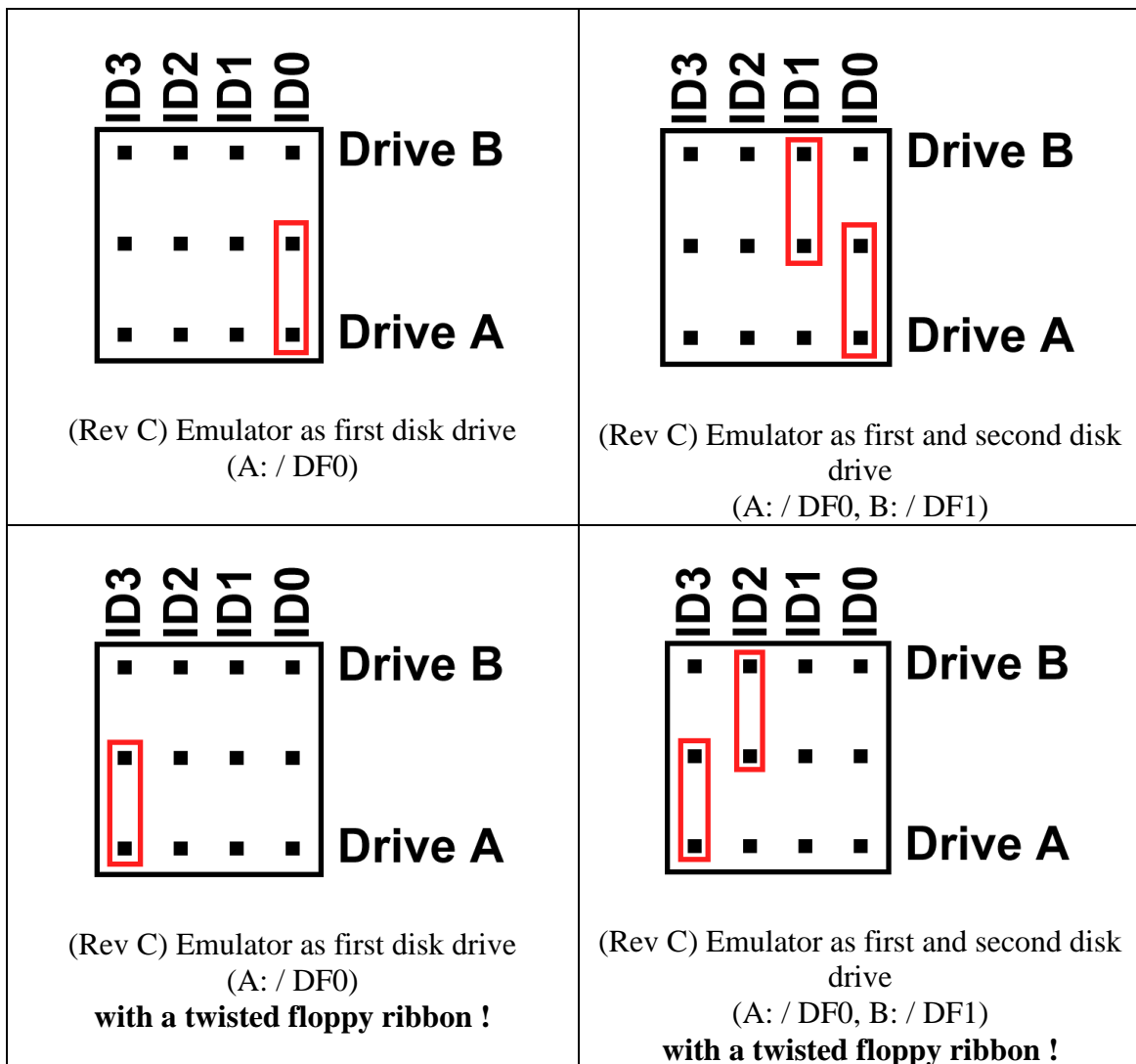

2.3.2 PC Compatible jumpers/switches settings

ID line	ID3	ID2	ID1	ID0
Host Line	/MOTEB	/DRVSA	/DRVSB	/MOTEA
Function	Motor Enable B	Drive Sel A:	Drive Sel B:	Motor Enable A

Table 3 : PC jumpers/switches setting

Note : If you are using a twisted floppy ribbon, the ID lines are reversed. In this case IDs lines assignments are reversed too:

ID line	ID3	ID2	ID1	ID0
Host Line	/MOTEA	/DRVSB	/DRVSA	/MOTEB
Function	Motor Enable A	Drive Sel B:	Drive Sel A:	Motor Enable B

Table 4 : PC jumpers/switches setting (twisted floppy ribbon)

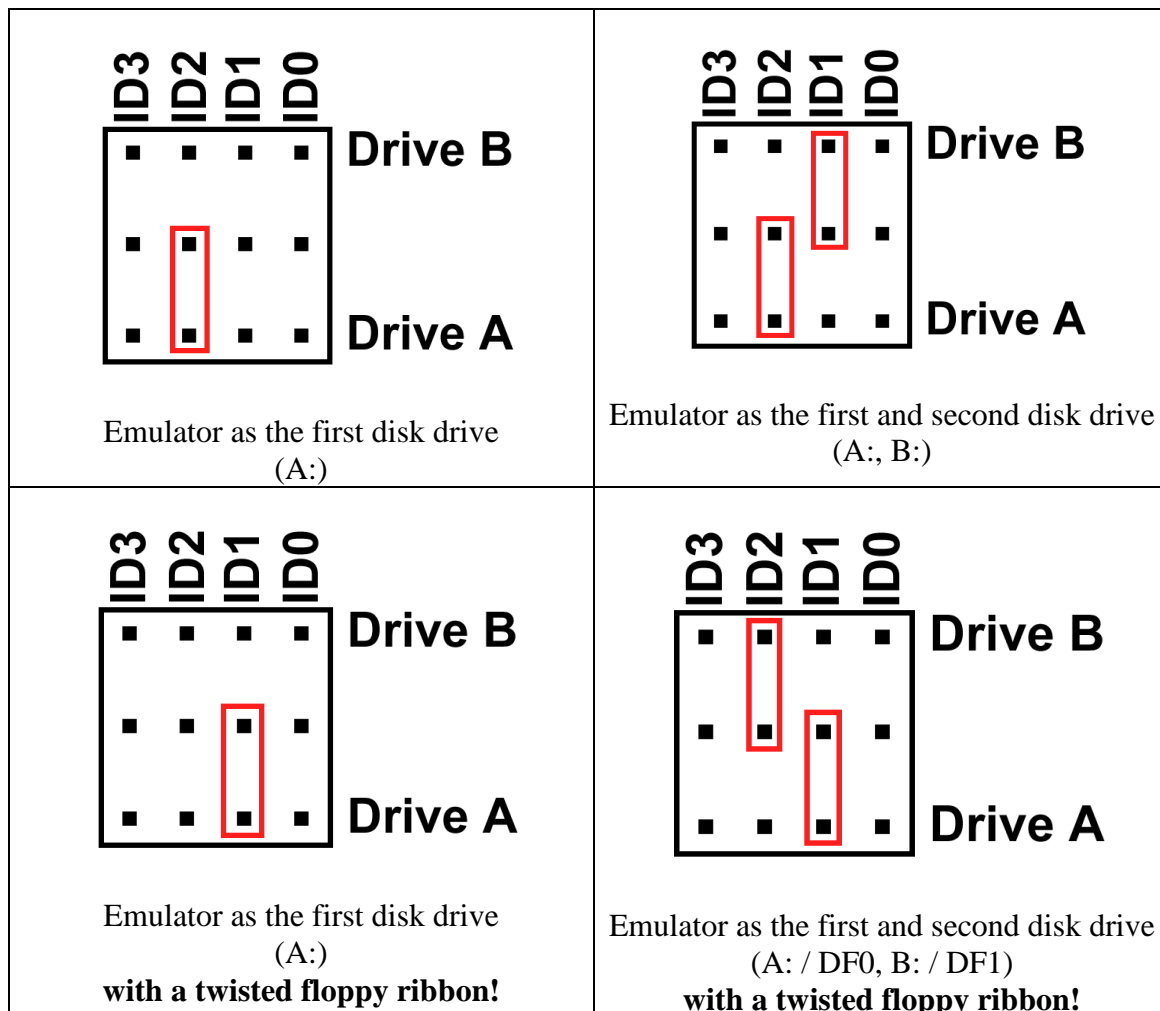

2.3.3 Amstrad CPC6128 jumpers/switches settings

Below the possible jumpers/switches settings for Amstrad CPC 6128 (external port connection).

<div style="text-align: center;"> <p>ID3 ID2 ID1 ID0</p> <table border="1" style="margin: auto; border-collapse: collapse;"> <tr> <td style="text-align: center;">■</td> <td style="text-align: center;">■</td> <td style="text-align: center;">■</td> <td style="text-align: center;">■</td> <td style="padding-left: 10px;">Drive B</td> </tr> <tr> <td style="text-align: center;">■</td> <td style="text-align: center;">■</td> <td style="text-align: center;">■</td> <td style="text-align: center;">■</td> <td></td> </tr> <tr> <td style="text-align: center;">■</td> <td style="text-align: center;">■</td> <td style="text-align: center;">■</td> <td style="text-align: center;">■</td> <td style="padding-left: 10px;">Drive A</td> </tr> </table> <p style="text-align: center;">Emulator as the first disk drive</p> <p>Note : In this case the internal floppy disk drive must be disabled. To do this you can connect wire 23 of the external floppy ribbon to the ground (wire 24), or simply unplug the floppy ribbon from the internal disk drive.</p> </div>	■	■	■	■	Drive B	■	■	■	■		■	■	■	■	Drive A	<div style="text-align: center;"> <p>ID3 ID2 ID1 ID0</p> <table border="1" style="margin: auto; border-collapse: collapse;"> <tr> <td style="text-align: center;">■</td> <td style="text-align: center;">■</td> <td style="text-align: center;">■</td> <td style="text-align: center;">■</td> <td style="padding-left: 10px;">Drive B</td> </tr> <tr> <td style="text-align: center;">■</td> <td style="text-align: center;">■</td> <td style="text-align: center;">■</td> <td style="text-align: center;">■</td> <td></td> </tr> <tr> <td style="text-align: center;">■</td> <td style="text-align: center;">■</td> <td style="text-align: center;">■</td> <td style="text-align: center;">■</td> <td style="padding-left: 10px;">Drive A</td> </tr> </table> <p style="text-align: center;">Emulator as the second disk drive</p> <p>(type b to select the floppy emulator, and a to select the internal disk drive)</p> </div>	■	■	■	■	Drive B	■	■	■	■		■	■	■	■	Drive A
■	■	■	■	Drive B																											
■	■	■	■																												
■	■	■	■	Drive A																											
■	■	■	■	Drive B																											
■	■	■	■																												
■	■	■	■	Drive A																											

3 Quick step by step guide

This guide shows you how to basically use the SD HxC Floppy Emulator.

Note : An archive with ready-to-use configuration files and file images for different machines is available at this address :

https://hxc2001.com/download/floppy_drive_emulator/QuickInstall_FloppyDiskImages.zip

3.1 Install the SD HxC Floppy Emulator

Remove the original floppy disk drive from the host machine and replace it with the SD HxC Floppy Emulator.

Please read the “[Hardware requirement/setup](#)” section (Page 6) for more details about connections and jumpers/switches settings.

3.2 Prepare the SD Card

► Format the SD Card in FAT32

To use the SD Card with the SD HxC Floppy Emulator this one must be formatted in **FAT32 or FAT16 (FAT32 recommended)**. Others file systems are currently not supported.

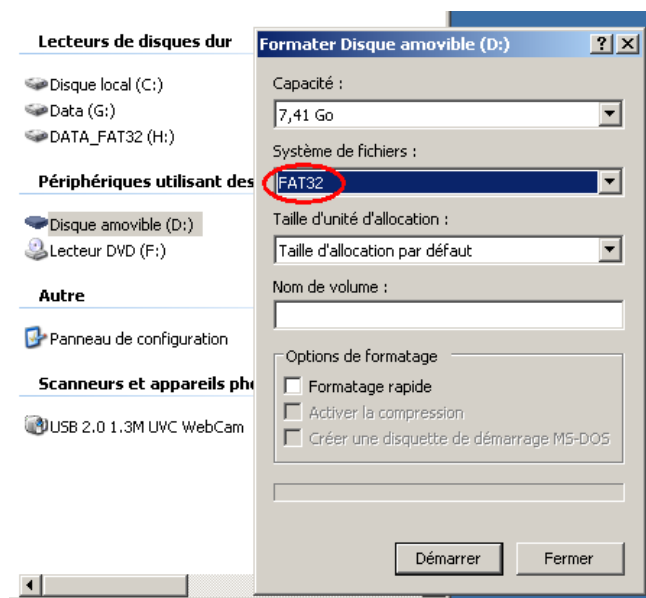

Figure 9 : Format the SD Card in FAT32

► Copy the **HXCSDFE.CFG** file into the SD Card

The SD HxC Floppy Emulator need the **HXCSDFE.CFG** configuration file to be present on the SD Card. This file contains the floppy emulator settings and the path of last used/selected floppy image.

The **HXCSDFE.CFG** configuration file can be generated with the HxC Floppy Emulator software or can be found in the firmware zip file:

https://hxc2001.com/download/floppy_drive_emulator/SDCard_HxCFloppyEmulator_firmware.zip

For more informations about the SD HxC Floppy Emulator settings please go to [the SD HxC Floppy Emulator settings window chapter](#) (page 19).

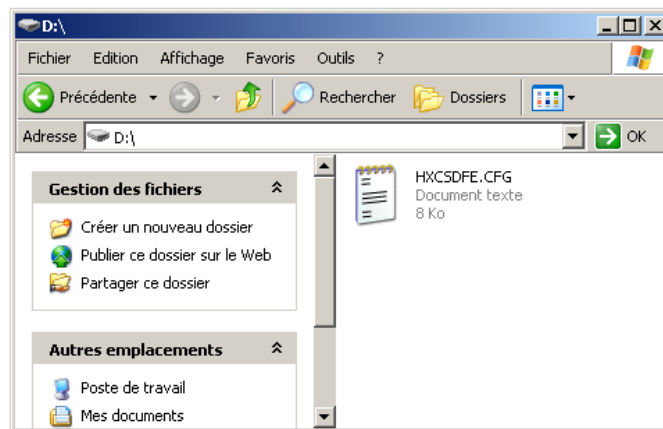

Figure 10 : Copy HXCSDFE.CFG to the SDCard

NOTE: If you want to use the Atari ST/Amiga/CPC floppy image file selector software, copy the **AUTOBOOT.HFE** file after the HXCSDFE.CFG file.

For more details please go to the [SD HxC Floppy Emulator file selector section](#) (page 24).

3.3 Convert/Copy floppy images to the SD Card

The HxC Floppy Emulator software can be used to create, convert and manage floppy disk images files for the SD HxC Floppy Emulator.
This software can be started by double-clicking on the HxCFloppyEmulator.exe executable.

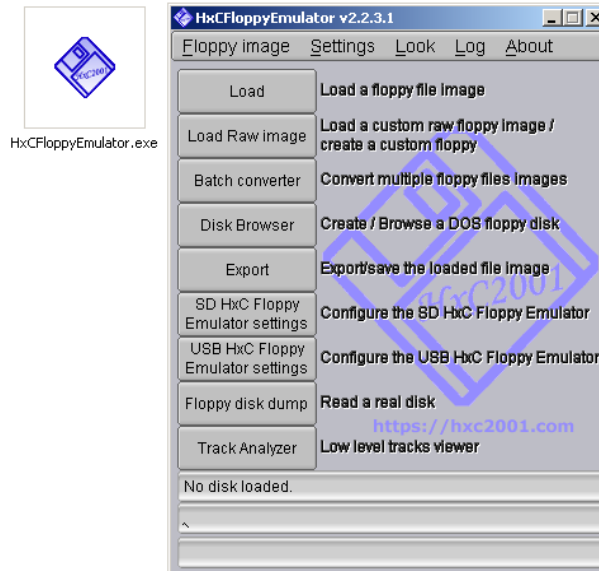

Figure 11 : Start the HxCFloppyEmulator software

► Use the “Batch converter” function

You can use the Floppy disk images batch converter to convert a large quantity of floppy images. To do this, click on the <<Batch converter>> button. The following window should appear:

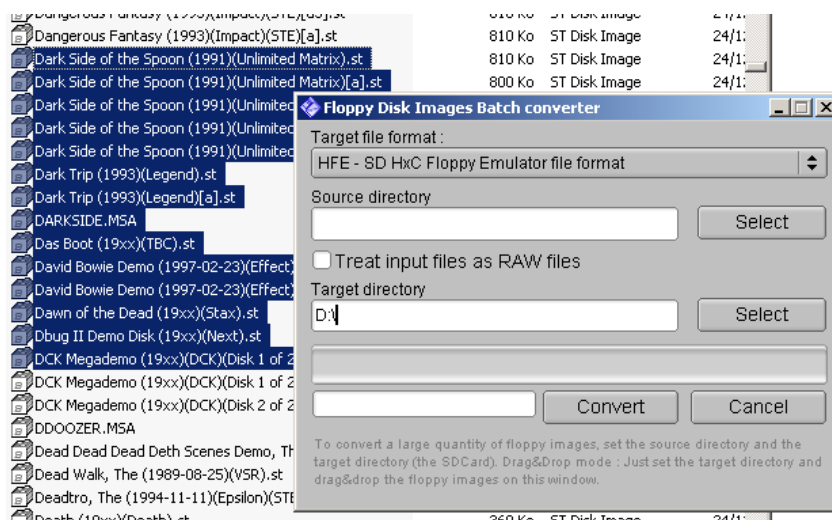

Figure 12 : Batch converter window

Choose the SD Card disk drive (D: here) as target directory.
For the SD HxC Floppy Emulator the target file format must be set to HFE.

Drag and drop on the window all floppy images you want to convert and copy to the SD Card.

Once done, the SD Card contains HFE floppy images.

The SD Card is ready, you can insert it in the SD HxC Floppy Emulator.

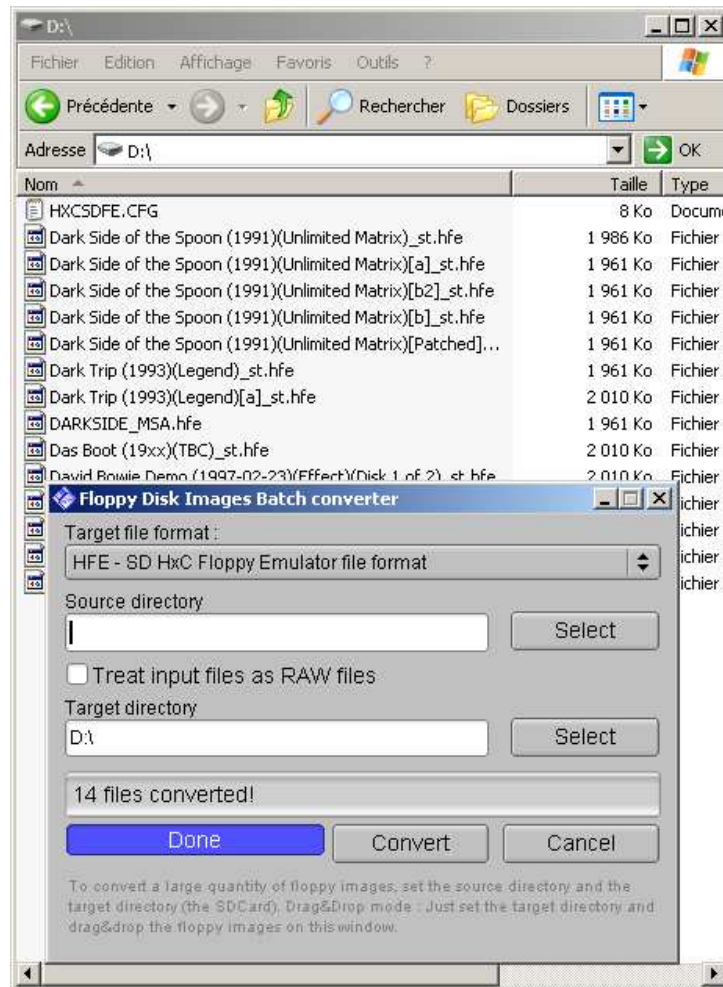

Figure 13 : HFE files after conversion

Note 1: You can recursively convert a folder and its subfolders by specify its path in the “Source directory” field.

Note 2: A HFE file can be converted back to a standard floppy image : ADF,IMG,IMD,... You just need to change the Target file format field.

3.4 Use the SD Card with the SD HxC Floppy Emulator

Note : Pictures show the SD HxC Floppy Emulator Rev C, but usage is exactly the same on the Rev F.

When you insert the SD Card into the emulator you should be able to browse the SD Card floppy images with the ◀ (left) and ▶ (right) buttons. Use the ▾ (select) button to enter a subfolder or load a floppy image disk.

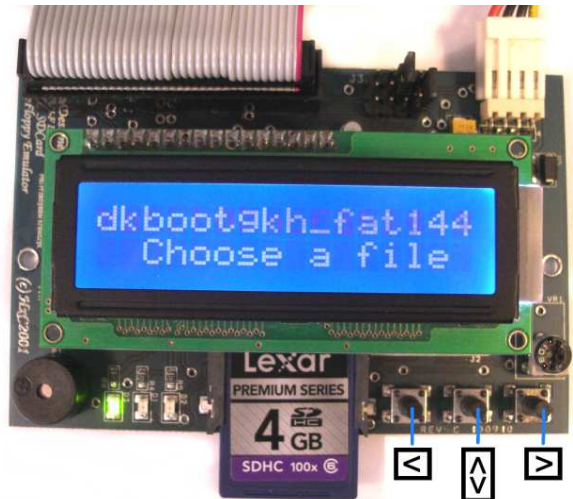



Figure 14 : Browse the SD Card



Figure 15 : Floppy image disk loaded

The floppy disk image is selected and can be accessed by the host machine.

To eject the floppy disk image press  briefly.

You can also directly change floppy disk images by pressing  or  buttons.

If you want to come back to the disk drive selector menu, in order to insert another floppy image to the other virtual disk drive, press  until this menu appear.

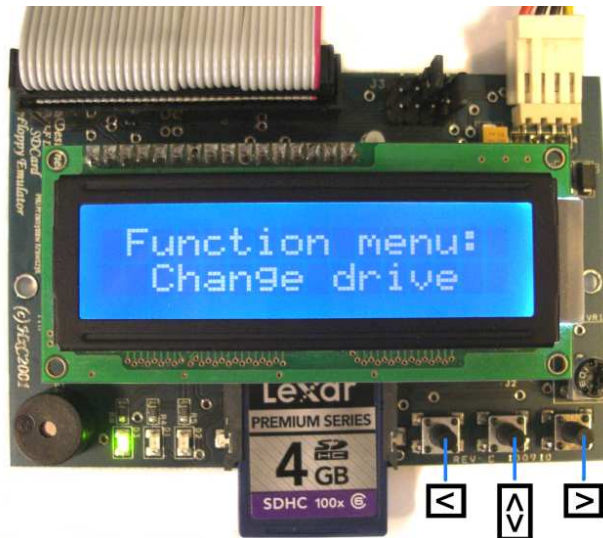

Figure 16 : Drive menu

Then choose the drive and select the image insert in this drive.

Note: The floppy write protect can be set/unset by using the SD Card write protect switch.



Figure 17 : SD Card write protect switch

3.5 Internal settings menu

Internal settings that can be changed on the emulator directly into the embedded settings menu. You generally don't have to change them as the default values are fine in most cases. Anyway if needed, you can access to the internal settings menu. To access it, remove the SD Card and press the select button ()

Then you can navigate through the various available options.

4 HxC Floppy Emulator software

The HxC Floppy Emulator software allows you to convert or create floppy image files for the SD HxC Floppy Emulators.

The list of supported file image format can be found in Supported file format / Input (page 31) or on the SD HxC Floppy Emulator project page :

http://hxc2001.free.fr/floppy_drive_emulator/

4.1 Main window

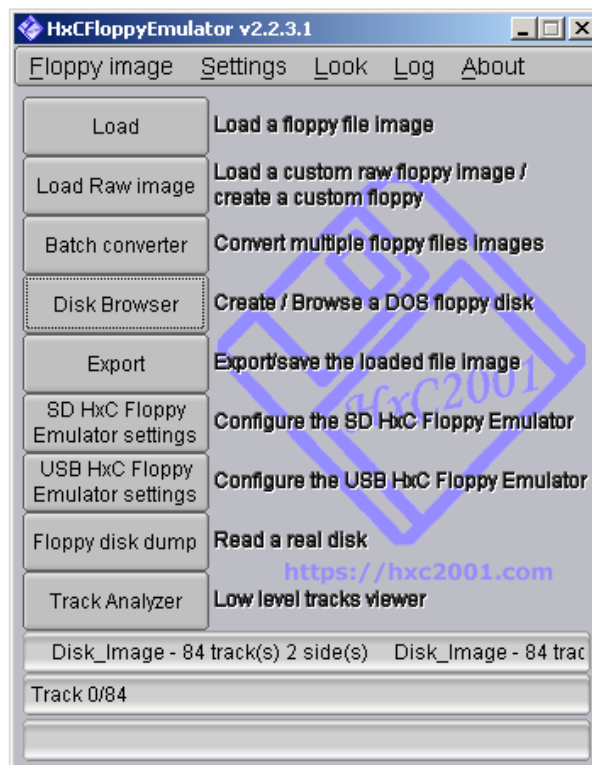

Figure 18 : HxCFloppyEmulator software functions

This window allows you to :

- | | |
|---|--|
| ▶ <u>Load & Load Raw image:</u> | Load a floppy image. |
| ▶ <u>Batch converter:</u> | Convert automatically a folder of floppy images. |
| ▶ <u>Disk Browser:</u> | Create/Browse a MS DOS or Amiga DOS floppy disk. |
| ▶ <u>Export:</u> | Export/convert the loaded floppy image. |
| ▶ <u>SD HxC Floppy Emulator settings:</u> | Edit/create the HXCSDFE.CFG file. |
| ▶ <u>USB HxC Floppy Emulator settings:</u> | Change the USB HxC Floppy Emulator settings. |
| ▶ <u>Floppy disk dump:</u> | Dump a floppy disk and load it. |
| ▶ <u>Track Analyzer:</u> | View/check the loaded disk format/layout |

4.2 SD HxC Floppy Emulator settings window

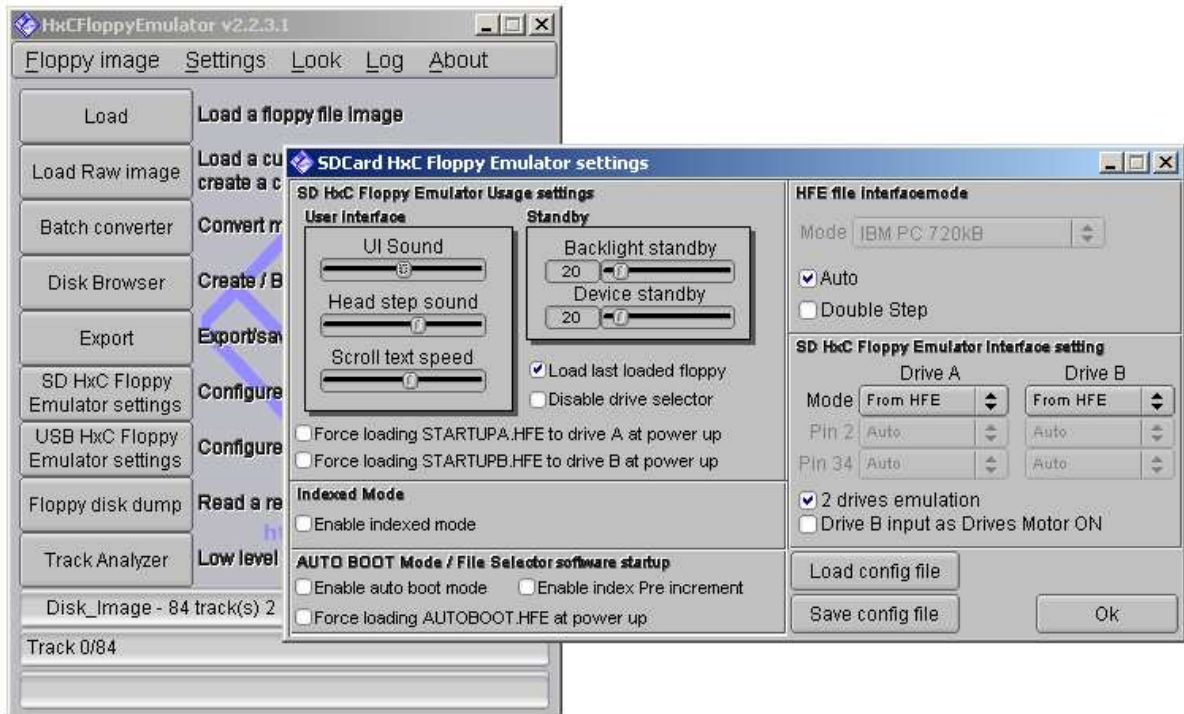

Figure 19 : SD HxC Floppy Emulator settings window

This window allows you to create/edit the HXCSDFE.CFG file to change the behavior of the emulator. Please note that most of these settings are also available on the emulator embedded settings menu.

► **UI sound :**

This slide can be used to change the floppy emulator user interface sound level.

► **Head step sound :**

This slide can be used to change the floppy emulator head step sound level.

► **Backlight standby :**

This slide can be used to change LCD backlight power off timing.

► **Device standby :**

This slide can be used to change standby timing.

► **Load last loaded floppy :**

If checked, the last selected floppy image are auto-loaded at power up.

► **Disable disk drive selector :**

If checked, the drive selection is disabled.

► **Enable auto boot mode :**

If checked, the autoboot.hfe file is loaded at power up. If you intend to use a floppy image software selector, this feature must be set.

► **HFE file interface mode :**

The floppy interface mode are automatically set into the SD HxC Floppy Emulator file image (HFE). To force/change the floppy disk interface mode, before converting files, uncheck "Auto" and choose the wanted floppy interface mode.

4.3 Custom raw file image loader / floppy generator

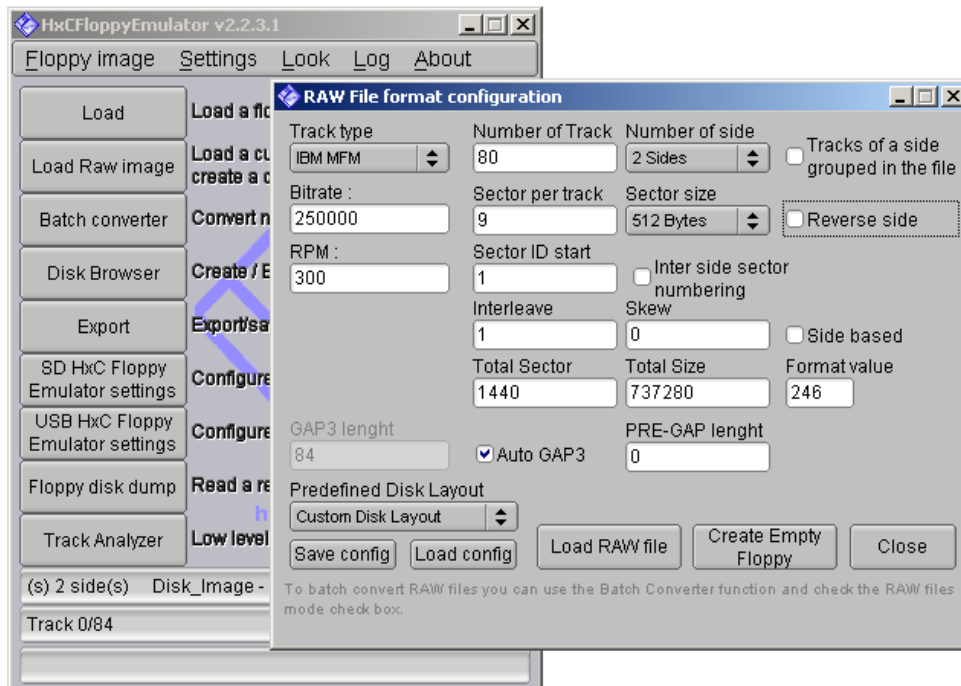

Figure 20 : RAW file loader window

This window allows you to specify a custom floppy disk format and load raw files using your settings. You can also generate/format a virtual floppy according to your settings with the “Create Empty Floppy” button.

- ▶ **Track type :** Specify the track format : MFM(DD) or FM (SD).
- ▶ **Two sides floppy :** If checked 2 sides (DS), otherwise 1 one side floppy (SS).
- ▶ **Reverse side :** Exchange side 0 and side 1.
- ▶ **Track of a side grouped in the file :** If checked the first half part of the file contains side 0 tracks only, and the other half part contains side 1 tracks.
- ▶ **Number of tracks :** Specify the number of tracks per side on the floppy disk.
- ▶ **Sectors per track :** Specify the number of sectors on a track.
- ▶ **Sectors size :** Specify the sectors size.
- ▶ **Sector ID start :** Specify the starting sector ID (commonly set to 1).
- ▶ **GAP3 length :** Specify the GAP3/inter sector gap length.
- ▶ **Interleave :** Specify the sectors interleave.
- ▶ **Skew :** Specify the tracks skew.
- ▶ **Bitrate :** Specify the tracks bitrate (common values are : 250000, 300000, 500000...).
- ▶ **RPM :** Specify the disk rotation speed (common values are : 300, 360, 600).

Predefined floppy disk formats are available in the “Predefined Disk Layout” menu for many machines.

4.4 Floppy disk dump feature

This function allows you to read real floppy disks to use their images on the SD HxC Floppy Emulator. This tool is able to read most of ISO/IBM MFM(DD/HD) or FM (SD) floppy disk.

To use this function your PC must be equipped with the right floppy disk drive (8" 5"1/4 or 3"1/2) connected to the motherboard. USB floppy disk drives are not supported.

This feature is based on fdrawcmd for Windows developed by Simon Owen. You can download the latest version of this driver on this site :

<http://simonowen.com/fdrawcmd>

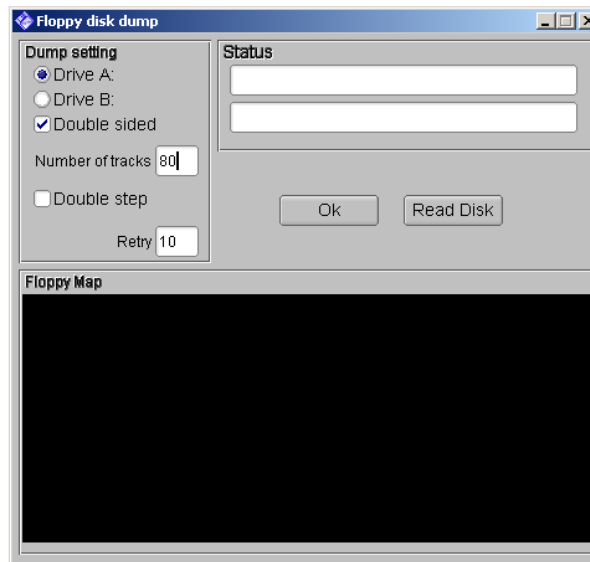

Figure 21 : Floppy dump window

The settings depend on the disk type you need to dump. Below you will find some safe settings:

Floppy Disk Drive model	Safe track setting
1.44MB/720KB 3"1/2	80 tracks and 2 sides.
1.2MB 5"1/4	80 tracks and 2 sides.
360KB 5"1/4	40 tracks and 2 sides.
8"	77 tracks and 2 sides.

During reading, the format/encoding mode/bitrate, number of sector and sector layout of each track is automatically determined by the tool and displayed in the status field. Once done, the floppy disk image is loaded on the main window. You have to export it into HFE to use it with the emulator.

Note: The default floppy interface mode of dumped floppy disk is set to <<Generic Shugart>>. If the targeted system use another floppy interface mode (PC for example) don't forget to change this setting in the [SD HxC Floppy Emulator settings](#) (more details on page 19) before exporting the floppy image.

Caution: Be careful with the Number of tracks setting ! A too high value may damage the floppy disk drive during reading.

Note: If you are reading an 5"1/4 360KB floppy disk on an 5"1/4 1.2MB disk drive, set the Double step feature and set the number of tracks to 40.

4.5 DOS Floppy disk browser

The HxC Floppy Emulator software is able to generate a virtual floppy disk based on MS DOS or AmigaDOS files systems. This feature allows you to generate a MS DOS or AmigaDOS floppy disk containing your files.

To generate a FAT12/MS DOS floppy disk, click on the “Disk Browser” button and choose the target floppy format (Example : 3”5 1.44MB DSHD FAT12 floppy).

Then drag and drop the files/folders to copy to the virtual floppy disk on the window. Once done you have just to export the created floppy image into HFE file and copy it to the SD Card.

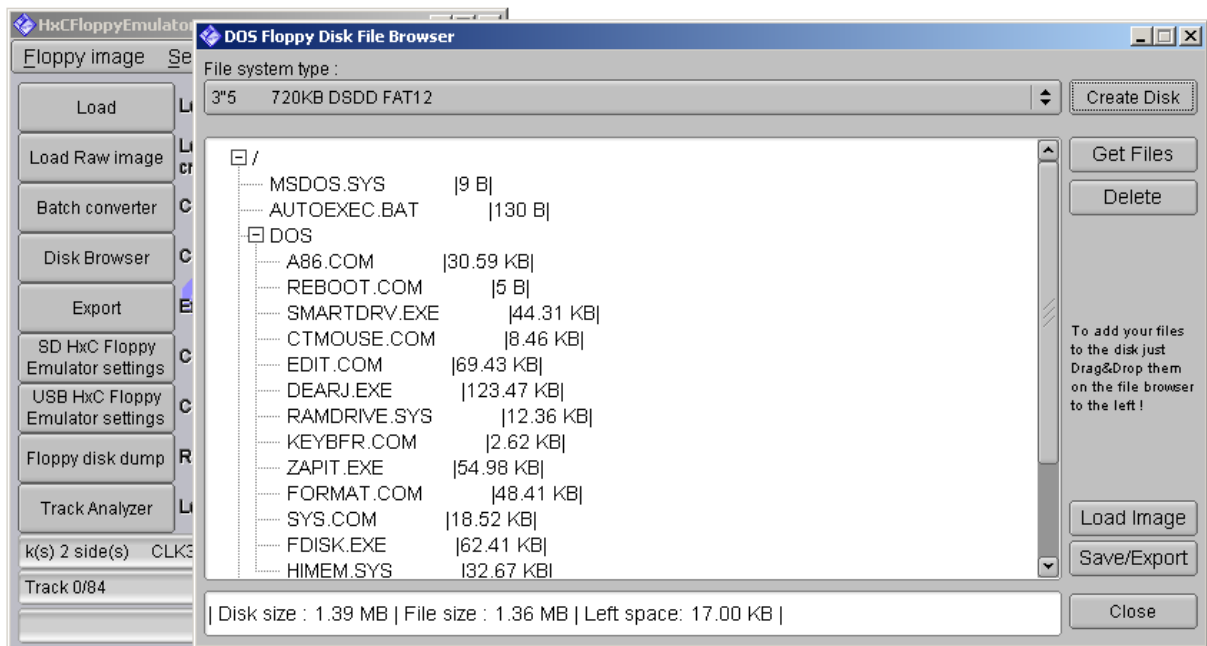

Figure 22 : DOS floppy disk file browser window

Note: By adding an extension to the name to the folder containing the floppy files/folders you can generate the floppy disk by drag & drop it to the HxC Floppy Emulator software window.

For example if you drag and drop a folder with the name “myfloppydisk.fat1440”, a 1.44MB MS DOS floppy is generated.

5 SD HxC Floppy Emulator file selector software

The SD HxC Floppy Emulator file selector software is a tool running on the host computer. This tool allows you to select floppy file image directly with the host computer keyboard and screen. The LCD usage is then optional and only one push button is needed on the emulator.

This tool is currently available on Amiga, Atari and Amstrad CPC machines.

To use this tool, copy the AUTOBOOT.HFE to the root of the SD Card and set the "Enable auto boot mode" feature (page 19 for more details).

The last version of the tool can be downloaded from github :

https://github.com/jfdelnero/HXCFE_file_selector

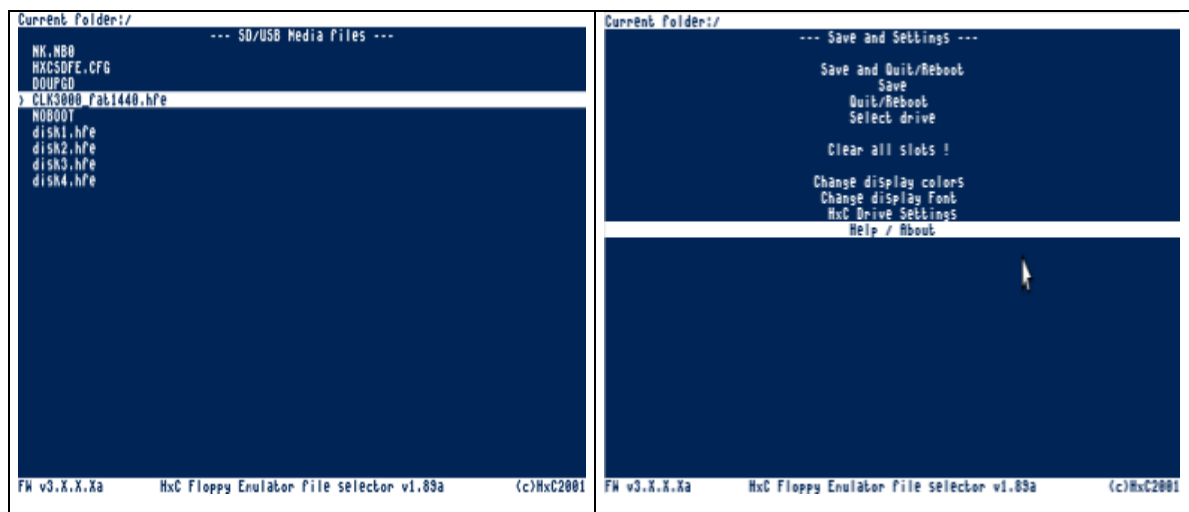



Figure 23 : File image selector main page and settings menu

Once started you can see and browse the content of the SD Card.
To get the help page, press the key "HELP".

Basically you can select a file image and reboot with it, or make a "slot list" with multiple disk.

Once rebooted, the floppy disk emulator buttons assignment change to:

Button  : Previous Slot.

Button  : Next Slot

Button  : Select first slot (AUTOBOOT.HFE)

Each time another image is selected the slot number is indicated by the buzzer and the SD access LED.

Note : If you press any button more than 1s, the first slot/selector software is selected. In this case only one push button is needed.

6 SD HxC Floppy Emulator firmware update

SD HxC Floppy Emulator Update procedure :

► Download the last firmware version:

https://hxc2001.com/download/floppy_drive_emulator/SDCard_HxCFloppyEmulator_firmware.zip

► Copy the new firmware file (*.upd) to a freshly formatted **FAT32** SD Card.

► Insert the SD Card into the emulator.

► Press Left and Right buttons before power up and keep it pressed at least 1 seconds at power up.

► Wait some seconds its done !

Note 1:

The file must be unfragmented on the SD Card and must be in the first part of the root directory.

For these reasons it is recommended to use a freshly formatted **FAT32** SD Card, otherwise you may get the error 4 or 6 (see note 2).

Note 2:

Bootstrap LED error messages:

Error 1 : (blink 1 time and 2 seconds pause cycle) No entry point (->no software flashed)

Error 2 : (blink 2 time and 2 seconds pause cycle) SDCard init error.

Error 3 : (blink 3 time and 2 seconds pause cycle) FAT error.

Error 4 : (blink 4 time and 2 seconds pause cycle) UPD File not found!

Error 5 : (blink 5 time and 2 seconds pause cycle) Bad UPD File header! (bad file)

Error 6 : (blink 6 time and 2 seconds pause cycle) Bad data CRC! (file corrupted)

Error 7 : (blink 7 time and 2 seconds pause cycle) Bad data size!

Error 8 : (blink 8 time and 2 seconds pause cycle) Write error (PIC flash error)

7 Technical details

7.1 Floppy interface

- HE10 34 pins floppy connector
- Shugart compatible mode supported.
- PC compatible mode supported.
- 24 mA driving capability.
- Two floppy disk drives emulation.
- 300, 360 and 600 RPM supported (others RPM possible).
- Up to 255 tracks
- Up to 2 Sides

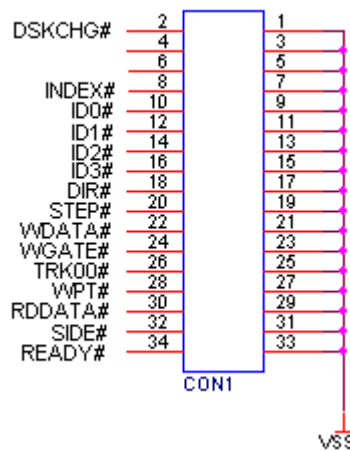

Figure 24 : Floppy connector pinout

7.2 Power supply

- 5V +/- 10% standard power floppy connector input.
- 500mA max current consumption. (Standby :100mA, RD/WR:170mA min – 450mA max. depend on the SD Card)

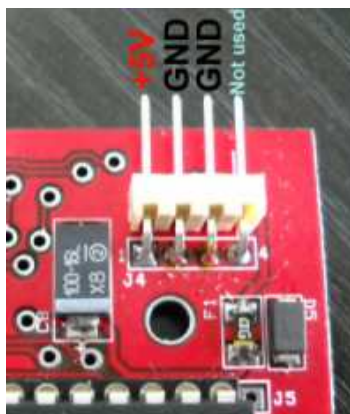

Figure 25 : Power connector pinout

7.3 User Interface

- 3 LEDs:
 - Power LED
 - Floppy access LED
 - SD Card access LED
- 3 buttons ("Previous", "Select/Eject", "Next").
- 1 audio transducer (Head Step and User interface sound).
- Detachable 2*16 chars Alphanumerical LCD.
(Note : LCD and buttons can be put on an external front panel)
- On screen display software for Amiga, Atari ST and Amstrad CPC computers.

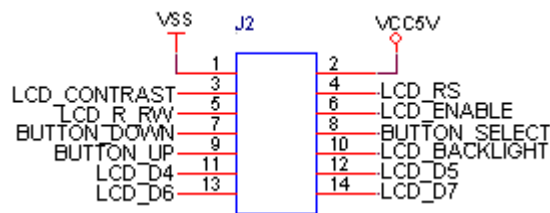

Figure 26 : Front panel connector pinout (Rev C only)

7.4 SD Card support

- SD Card up to 2GB.
- SDHC Card supported up to 32GB.
(10Mhz SPI bus mode. Average throughput : ~500KB/s)

7.5 SD Card File-system

- FAT32/FAT16 supported. Subdirectory and long name file supported.

7.6 Read / Write support

Track mode based floppy emulator (Full track pre-encoded in the HFE image file)

- Read support:
 - Most of existing formats (FM/MFM/Amiga track...) supported.
 - Custom tracks supported.
- Write support:
 - ISO MFM (DD) 128 Bytes-sector
 - ISO MFM (DD) 256 Bytes-sector
 - ISO MFM (DD) 512 Bytes-sector
 - ISO MFM (DD) 1024 Bytes-sector
 - ISO MFM (DD) 2048 Bytes-sector
 - ISO MFM (DD) 4096 Bytes-sector
 - ISO FM (SD) 128 Bytes-sector
 - ISO FM (SD) 256 Bytes-sector
 - ISO FM (SD) 512 Bytes-sector
 - ISO FM (SD) 1024 Bytes-sector
 - ISO FM (SD) 2048 Bytes-sector
 - ISO FM (SD) 4096 Bytes-sector
 - Amiga track write support (since the PCB revision C)
 - E-mu track write support (since the PCB revision C)

7.7 Floppy bitrate supported

- 250/300Kbits/s (SD/DD floppies)
- 500Kbits/s (HD floppies)
(others bit rates possible)

Note : Variable bit rate is not supported for the moment. So protected floppy disk image (IPF and STX file format) file support is only partial ! If you look for a device supporting IPF / STX please have a look to the [USB HxC Floppy Emulator device](#).

7.8 Additional features

- Firmware update with the SD Card.
- Last Loaded Floppy Image autostart at power up.
- Fast floppy image loading (<<1second), no conversion time.
- SD Card Direct Access mode : Floppy to SD bridging.

7.9 Mechanical drawing

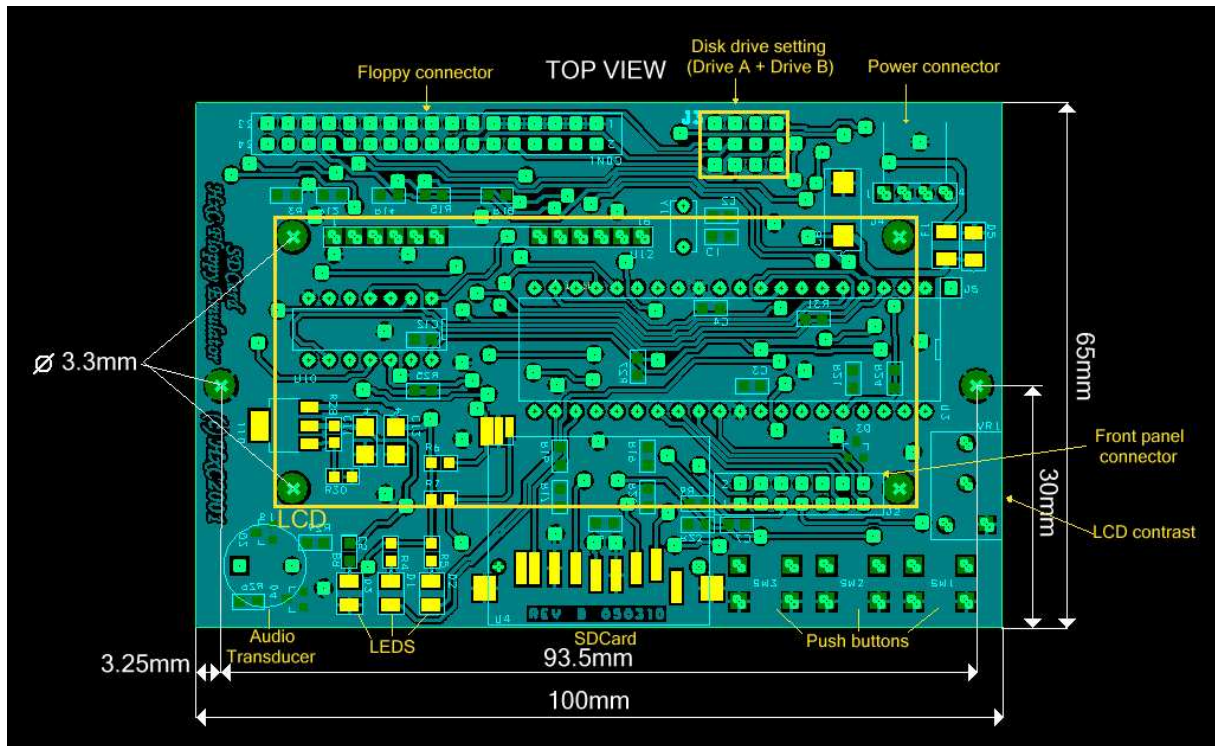

Figure 27 : Rev C Mechanical drawing

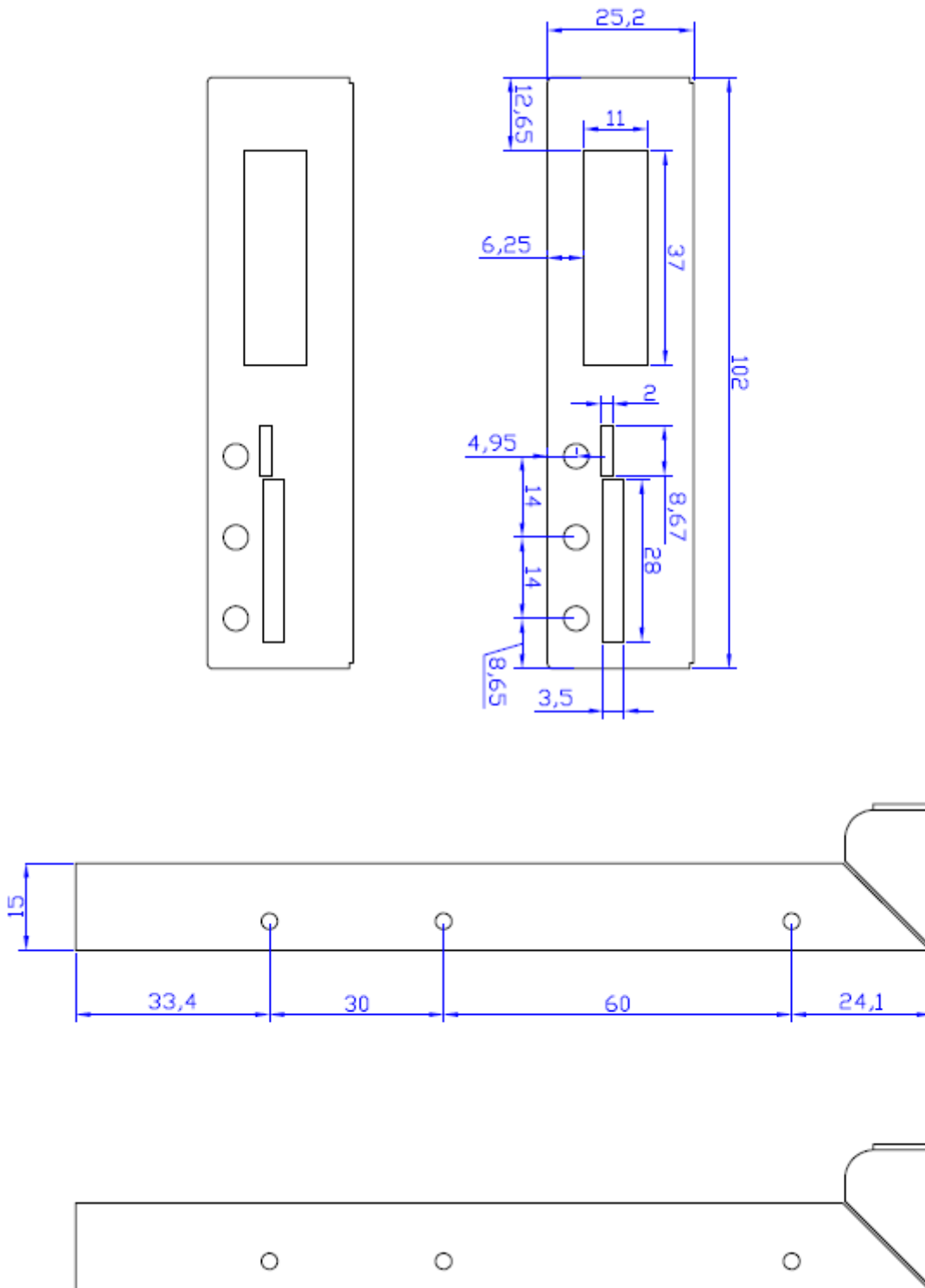

Figure 28 : Rev F Mechanical drawing

7.10 HxC Floppy Emulator software supported file formats

File format / Input	File extension
ABB/Asea 3"5 DD Floppy Disk	All RAW file types (IMG,DSK...)
ABB/Asea 3"5 DD Floppy Disk (ABB IRB2000 S3 - Single sided)	All RAW file types (IMG,DSK...)
Acorn ADF	*.adf
Acorn ADFL 640K Floppy Disk	All RAW file types (IMG,DSK...)
Acorn ADFM 320K Floppy Disk	All RAW file types (IMG,DSK...)
Acorn ADFS 160K Floppy Disk	All RAW file types (IMG,DSK...)
AED 6200P Floppy Disk Storage System Disk Layout	All RAW file types (IMG,DSK...)
Akai S3000 3"5 HD Floppy Disk	All RAW file types (IMG,DSK...)
Akai S900/S950 3"5 DD Floppy Disk	All RAW file types (IMG,DSK...)
Akai S950 3"5 HD Floppy Disk	All RAW file types (IMG,DSK...)
Amiga ADF	*.adf
Amiga ADZ	*.adz
Amiga DMS	*.dms
Amiga EXTENDED ADF	*.adf
Amiga FS	*.Amigados
Amiga OLD EXTENDED ADF	*.adf
Amstrad CPC DSK	*.dsk
AnaDisk file	*.ana
Apple II DO	*.do
Apple II NIB	*.nib
Apricot	*.dsk
Arburg RAW	*.arburgfd
Atari ATR	*.atr
Atari ST 3"5 DD Floppy Disk	All RAW file types (IMG,DSK...)
Atari ST DIM	*.dim
Atari ST MSA	*.msa
Atari ST ST	*.st
Atari ST STT	*.stt
Atari ST STX/Pasti	*.stx
Automatix RAIL DD 400KB Floppy Disk	All RAW file types (IMG,DSK...)
BBC ADL floppy image	*.adl
BBC SSD & DSD floppy image	*.dsd
BMP floppy layout (disk) image generator	*.bmp
BMP floppy tracks layout image generator	*.bmp
C64 D64 file image	*.d64
C64 D81	*.d81
ComputersLynx	*.ldf
Casio FZ1 3"5 HD Floppy Disk	All RAW file types (IMG,DSK...)
Casio FZF file	*.fzf
Coat-A-Matic 9400 / Robox RC9400	All RAW file types (IMG,DSK...)
COMX35 DS 140KB Floppy Disk	All RAW file types (IMG,DSK...)
COMX35 SS 140KB Floppy Disk	All RAW file types (IMG,DSK...)
COMX35 SS 70KB Floppy Disk	All RAW file types (IMG,DSK...)
COPYQM IMG	*.dsk
Dec RX55 Floppy Disk	All RAW file types (IMG,DSK...)
Didaktik Spectrum DD Floppy Disk	All RAW file types (IMG,DSK...)

DRAGON32 & 64 VDK	*.vdk
Dynacord Add-One Floppy Disk	All RAW file types (IMG,DSK...)
Dynacord HD 1.6MB Floppy Disk	All RAW file types (IMG,DSK...)
Emax 3"5 DD Floppy Disk	All RAW file types (IMG,DSK...)
EMAX EM1 & EM2	*.em1 / *.em2 / *.emx
Emax II 3"5 DD Floppy Disk	All RAW file types (IMG,DSK...)
E-mu Emulator I dsk	*.emufd
E-mu Emulator II *.eii	*.eii
E-mu Emulator II / SP1200 dsk	*.emuifd / *.sp1200fd
Ensoniq EDE (EPS/ SQ-80/VFX-SD)	*.ede
Ensoniq EPS 3"5 DD Floppy Disk	All RAW file types (IMG,DSK...)
Ensoniq EPS 3"5 HD Floppy Disk	All RAW file types (IMG,DSK...)
ENSONIQ GKH	*.gkh
Ensoniq Mirage 3"5 DD Floppy Disk	All RAW file types (IMG,DSK...)
Ensoniq Mirage EDM	*.edm
Excellon CNC6 Floppy Disk	All RAW file types (IMG,DSK...)
FAT12/MS DOS	*.fat
FAT12/MS DOS	*.fat
FEI	*.fei
FLP PC Magazine image	*.flp
GeneralMusic Gem S3 HD Floppy Disk	All RAW file types (IMG,DSK...)
GeneralMusic Gem WX Expander HD Floppy Disk	All RAW file types (IMG,DSK...)
Generic XML file	All RAW file types (IMG,DSK...)
Gravograph ISIS 3"5 DD Floppy Disk	All RAW file types (IMG,DSK...)
Heathkit	*.h8d
HxC AFI file	*.afi
HXC MFM IMG	*.mfm
IBM PC IMG	*.img
IBM PC IMZ	*.imz
ImageDisk IMD file	*.imd
Korg DSS1 3"5 DD Floppy Disk	All RAW file types (IMG,DSK...)
Korg T3 3"5 HD Floppy Disk	All RAW file types (IMG,DSK...)
KryoFlux Stream	*.raw
Linn/Forat 9000 Floppy Disk	All RAW file types (IMG,DSK...)
Logical Interchange Format (LIF) 3"1/2 1232KB (HD)	All RAW file types (IMG,DSK...)
Logical Interchange Format (LIF) 3"1/2 264KB (single side)	All RAW file types (IMG,DSK...)
Logical Interchange Format (LIF) 3"1/2 616KB (double side)	All RAW file types (IMG,DSK...)
Logical Interchange Format (LIF) 5"1/4 264KB	All RAW file types (IMG,DSK...)
Memotech Floppy Disk (40 tracks)	All RAW file types (IMG,DSK...)
Memotech Floppy Disk (80 tracks)	All RAW file types (IMG,DSK...)
Microtan 65 TANDOS Floppy Disk	All RAW file types (IMG,DSK...)
MSX DSK	*.dsk
NEC D88	*.d88
NEC FDI	*.fdi
Oberheim DPX	*.dpx
Oerlikon Balzers 250KB SD Disks	All RAW file types (IMG,DSK...)
Olivetti TOP 100 / Triumph-Adler typewriter Quickdisk raw image	All RAW file types (IMG,DSK...)
Oric DSK	*.dsk

Oric Jasmin 357K Floppy Disk	All RAW file types (IMG,DSK...)
OS9 1280KB Floppy Disk	All RAW file types (IMG,DSK...)
OS9 640KB Floppy Disk	All RAW file types (IMG,DSK...)
Prophet 2000 / 2002	*.img
PUMA Robot arm 560C DD 640KB Floppy Disk	All RAW file types (IMG,DSK...)
RAW Sector	*.img
Roland W30 file	*.w30
Roland W30/S330/JW-50/W50/S50/S550 DD Floppy Disk	All RAW file types (IMG,DSK...)
SAB Diskette Utility	*.sdu
SAM COUPE MGT	*.mgt
SAM COUPE SAD	*.sad
SuperCard Pro SCP Stream	*.scp
SD Card HxCFE EXTENDED HFE file	*.hfe
SD Card HxCFE HFE file	*.hfe
SD Card HxCFE HFE file (HDDD A2 Support)	*.hfe
SD Card HxCFE HFE V3 file	*.hfe
Speccy DOS SDD File	*.sdd
Special 2.5MB DOS EXHD Floppy Disk	All RAW file types (IMG,DSK...)
Special 4.5MB DOS EXHD Floppy Disk	All RAW file types (IMG,DSK...)
Special 6.78MB DOS EXHD Floppy Disk	All RAW file types (IMG,DSK...)
Spectrum Opus Discovery	All RAW file types (IMG,DSK...)
SPS IPF	*.ipf
Standard 3" Amstrad CPC Floppy Disk	All RAW file types (IMG,DSK...)
Standard 3" Amstrad CPC Floppy Disk	All RAW file types (IMG,DSK...)
Standard 3"5 DOS DD Floppy Disk	All RAW file types (IMG,DSK...)
Standard 3"5 DOS ED Floppy Disk	All RAW file types (IMG,DSK...)
Standard 3"5 DOS HD Floppy Disk	All RAW file types (IMG,DSK...)
Stream HFE file	*.hfe
STW	*.stw
Super famicom SMC / Game Doctor	*.smc
SVD	*.svd
System 24	*.s24
Tatung Einstein DD 200KB Floppy Disk	All RAW file types (IMG,DSK...)
Tatung Einstein DD 400KB Floppy Disk	All RAW file types (IMG,DSK...)
TELEDISK TD0	*.td0
Thomson TO8D FD	*.fd
Thomson TO8D SAP	*.sap
TI99 4A PC99	*.pc99
TI99 4A V9T9	*.v9t9
Timex FDD3000 Floppy Disk (40 Tracks, 1 Side)	All RAW file types (IMG,DSK...)
Timex FDD3000 Floppy Disk (80 Tracks, 2 Sides)	All RAW file types (IMG,DSK...)
TRS80 DMK	*.dmk
TRS80 JV1	*.jv1
TRS80 JV3	*.jv3
TRS80 JVC	*.jvc
UKNC MFM 800KB Disk Layout	All RAW file types (IMG,DSK...)
Unitel Videotex Floppy Disk	All RAW file types (IMG,DSK...)
VEGAS6809 image	*.veg

VTR IMG	*.vtr
X68000 HDM file	*.hdm
ZX Spectrum FDI	*.fdi
ZX Spectrum SCL	*.scl
ZX Spectrum TRD	*.trd
FAT12 file system generator	Multi-platforms. PC – Keyboards/Samplers – CNC machines. More details on the page 23
RAW floppy loader/generator	Multi-platforms. Allow you to generate a custom floppy format. More details on the page 20
Floppy Disk reader	Multi-platforms. Allows you to read a real floppy disk. More details on the page 21

Note : This list is subject to changes since new files format support are regularly added. If you want a particular file format support don't hesitate to contact us (contact informations on page 36).

7.11 **Machines compatibility list**

The currently tested/supported Computers / Keyboards / Samplers / CNC / Robots can be find at this address :

https://hxc2001.com/download/floppy_drive_emulator/support.htm

If your hardware is not listed, feel free to contact us, we will evaluate the compatibility with the SD HxC Floppy Emulator.

7.12 Contact / Project page

The softwares and firmwares are regularly updated to add new features and fix bugs.
To get the latest software and firmware version please visit the project website:

<https://hxc2001.com>

To report issues and/or bugs please go to the project forum :

<http://torlus.com/floppy/forum>

or contact us by email:



Email :

hxc2001@hxc2001.com

©2006-2020 Jean-François DEL NERO / HxC2001 All rights reserved.

Jean-François DEL NERO
11 Rue Frédéric Magisson
75015 PARIS
France

Website : <https://hxc2001.com/>

These products are manufactured and sold by Lotharek:



LOTHAREK FHU Przemysław Krawczyk
Oświęcimska 2C /18
Świerklaniec 42-622
Polska/Poland
VAT N° PL6312246599
GIOS/WEEE N° E0016247W

Website : <https://lotharek.pl/>

© 2006-2020 Jean-François DEL NERO

© 2006-2020 HxC2001.

All rights reserved.