

Y-E DATA

Product

Specifications

Double Sided, Half-Height

8 Inch Floppy Disk Drive

YD-180-1601

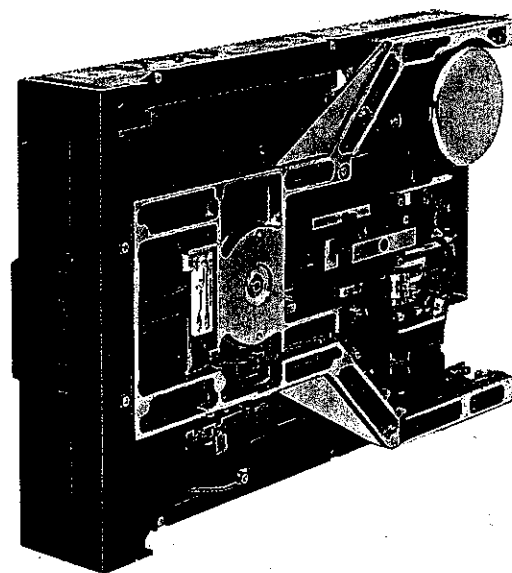

Y-E DATA Inc.
FDE-521004 REV. F

REVISION			
DATE	REV.	DESCRIPTION	REVISED PAGES
Sep 1981	A	ENGINEERING RELEASE	ALL
Mar 1982	B	REVISED PAGE	6, 18, 22, 27
Nov 1982	C	REVISED PAGE	14, 15, 18, 24, 30
Oct 1983	D	ADDED MOTOR ON/OFF OPTION PN27002-12 REV. C REVISED PAGE	9, 10, 11, 13, 16, 17, 18, 19, 20, 22, 23, 27, 30, 32
Mar 1984	E	REVISED PAGE	ALL
Aug 1985	F	New LSI PCB version PN127002-31 REV. A	i, ii, 2, 3, 4, 5, 7, 8, 11, 12 13, 14, 15, 16, 17, 20

Table of Contents

Chapter 1. General	1-1
Chapter 2. Specification Summary	2-1
2.1 Performance Specification.....	2-1
2.2 Installation Requirements.....	2-1
2.3 Reliability and Maintenance.....	2-2
Chapter 3. Electrical Interface	3-1
3.1 Signal Interface	3-1
3.1.1 Input Lines.....	3-1
3.1.1.1 Drive Select 1-4.....	3-1
3.1.1.2 Direction	3-3
3.1.1.3 Step.....	3-3
3.1.1.4 Write Data.....	3-3
3.1.1.5 Write Gate.....	3-3
3.1.1.6 Side Select.....	3-4
3.1.1.7 Low Current/Switch Filter.....	3-4
3.1.1.8 Head Load.....	3-4
3.1.1.9 In Use	3-4
3.1.2 Output Line.....	3-4
3.1.2.1 Index.....	3-4
3.1.2.2 Ready	3-5
3.1.2.3 Track 00.....	3-5
3.1.2.4 Write Protect	3-5
3.1.2.5 Read Data.....	3-5
3.1.2.6 Disk Change.....	3-5
3.1.2.7 Disk 2 sense.....	3-5
3.1.3 Alternate I/O Pins	3-6
3.1.4 Interface Circuits.....	3-6
3.1.5 Timing	3-7
3.1.5.1 Track Access Timing.....	3-7
3.1.5.2 Read Timing.....	3-7
3.1.5.3 Write Timing.....	3-8
3.2 Power Interface	3-8
3.2.1 DC Power.....	3-8
Chapter 4. Physical Interface	4-1
4.1 Head Load Options.....	4-2
4.2 Head Select Options	4-3
4.2.1 Head Select from Direction Line	4-3
4.2.2 Head Select for Up to Two Double Sided Drives.....	4-3
4.3 Radial Ready Options.....	4-3
4.4 Radial Index Options	4-4
4.5 In Use Options.....	4-4
4.5.1 In Use Led.....	4-4
4.5.2 Door Lock Latch Option	4-4
4.6 Write Protect Option.....	4-4
4.7 Disk Change.....	4-4
4.8 Two Sided.....	4-5
4.9 Switch Filter	4-5
4.10 Motor ON/OFF Option.....	4-5

Chapter 5. Physical Interface	5-1
5.1 Connectors and Cables.....	5-1
5.1.1 Signal Connectors and Cables (P1/J1).....	5-1
5.1.1.1 Connector J1.....	5-1
5.1.1.2 Connector P1 for a Flat Cable.....	5-2
5.1.1.3 Connector P1 for a Twisted Pair.....	5-2
5.1.2 DC Power Connector and Cable (P5/J5).....	5-2
5.2 Connector Pin Assignments.....	5-2
5.2.1 Signal Connector Pin Assignment.....	5-2
5.2.2 DC Connector Pin Assignment.....	5-3
5.3 Terminators.....	5-3
Chapter 6. Mounting	6-1
6.1 Drive Mechanical Dimensions.....	6-1
6.2 Mounting Recommendations.....	6-1
Chapter 7. IBM Compatibility	7-1
7.1 Track Positioning.....	7-1
7.2 Read/Write/Erase Head.....	7-1
7.3 Read Output Level.....	7-1
7.4 Write Current.....	7-1
7.5 Switch Filter.....	7-1
7.6 Index Positioning.....	7-1
Chapter 8. Double Density Recording	8-1

Table of Illustrations

2.1	Performance Specifications	2-1
2.2	Installation Requirements.....	2-1
2.3	Reliability and Maintenance	2-2
3.1	Input Circuit Electrical Specifications	3-1
3.2	Shorting Plugs.....	3-1
3.3	Interface Connections.....	3-2
3.4	Step	3-3
3.5	Write Data.....	3-3
3.6	Output Circuit Electrical Specifications	3-4
3.7	Index.....	3-4
3.8	Read Data.....	3-5
3.9	Signal Interface Circuits	3-6
3.10	Track Access Timing	3-7
3.11	Read Timing	3-7
3.12	Write Timing	3-8
3.13	Power Specifications.....	3-8
4.1	Functions.....	4-1
4.2	Customer Trace Options.....	4-2
4.3	Drive Select/Headload Option.....	4-3
4.4	Head Select for Two Double Sided Drives.....	4-3
4.5	In Use LED	4-4
4.6	In Use Timing	4-5
4.7	Internal Signal Option.....	4-5
4.8	Delay Time Option	4-5
4.9	Options with Interface Input.....	4-6
5.1	Interface Connection	5-1
5.2	J1 Connector Dimensions (Component Side)	5-1
5.3	Connector P1 for a Flat Cable	5-2
5.4	Connector P1 for a Twisted Pair	5-2
5.5	DC Power Connector and Cable.....	5-2
5.6	Signal Connector Pin Assignments	5-3
5.7	DC Connector Pin Assignments.....	5-3
6.1	Mounting Dimensions	6-1
7.1	Read Output Level.....	7-1
8.1	Double Density Recording.....	8-1

Chapter 1. General

The Y-E DATA Model YD-180 Floppy Disk Drive is a low cost direct access data storage device which utilizes a removable IBM or equivalent diskette as a storage medium.

It is compatible with the Y-E DATA Model YD-74C single sided Floppy Disk Drive, the Model YD-174D two-sided Floppy Disk Drive and the following IBM Floppy Disk Drives:

- * Single Sided IBM 3740 and System 32 Drives: 33FD
- * Two-Sided IBM 3600 and 4964 Drives: 43FD
- * Two-Sided Double Density IBM System 34 Drives: 53FD

The major features are as follows:

- (1) The YD-180 is half the height of a conventional 8" drive like the YD-174 (D), which permits the user to mount two YD-180's in place of one regular height drive.
- (2) Increase in storage capacity
Capacity on a two-sided single density diskette is 0.56 MB.
Capacity on a two-sided double density diskette is 1.2 MB.
(Diskettes are IBM or equivalent)
- (3) High speed accessing
Head access time is 3 ms track to track. Average random access time is 91 ms.
- (4) High reliability
The YD-180 uses a two-sided head carriage assembly with two proven ceramic R/W tunnel erase heads and flexured mounting.
- (5) Simplicity of operation
 - Daisy chain capability for up to four drives
 - Requires only +24 VDC and +5VDC. -12 VDC no longer needed.
 - Low power dissipation: 30W maximum. (55% of dissipation for YD-174 (D))
- (6) Standard specifications include
 - UL approved
 - ANSI plug to plug compatible
 - ISO WRITE PROTECT
 - Program controlled door lock and activity indicator LED on front panel
- (7) Aside from physical dimensions completely compatible with YD-174 (D)

Chapter 2. Specification Summary

2.1 Performance Specifications

	Single Density	Double Density
Capacity Unformatted Per Disk IBM Format Per Disk	0.8M Bytes 0.56M Bytes	1.6 M Bytes 1.2M Bytes
Recording Density	3408 BPI	6816 BPI
Track Density	48 TPI	48 TIP
Number of Cylinders	77	77
Number of Tracks	154	154
Recording Method	FM	MFM
Rotational Speed	360 RPM	360 RPM
Transfer Rate	250K Bits/sec	500 K Bits/sec
Latency (Average)	83 ms	83 ms
Access Time Average Track to Track Settling	91 ms 3 ms 15 ms	91 ms 3 ms 15 ms
Head Load Time	50 ms	50 ms
Motor Start Time	2 sec	2 sec

Table 2.1 Performance Specifications

2.2 Installation Requirements

DC Power Requirements	+24 VDC \pm 10%, 1.0A MAX. 0.4 TYP +5 VDC \pm 5%, 1.3A MAX. 0.4 TYP		
Power Dissipation	30W below, 10.4 TYP		
Environment		Operating	Storage
	Temperature	5°C to 43°C (41°F to 110°F)	-20°C to 60°C (14°F to 113°F)
	Relative Humidity	20 to 80% RH	8 to 80% RH
	Max. Wet Bulb	29°C (84°F)	No Condensation
Mechanical Dimensions	Height	57 mm (2.25 in)	
	Width	217 mm (8.55 in)	
	Depth	320 mm (12.6 ϕ in)	
	Weight	3.5 Kg (7.7 lbs.)	
Mounting	Horizontal front load, Vertical front load, Vertical top load.		

Table 2.2 Installation Requirements

(NOTE 1) Power voltage is specified at the drive side.

(NOTE 2) Refer to section 3.2 for DC supply current when multiple drives are installed.

(NOTE 3) Refer to section 6.2 for the mounting.

2.3 Reliability and Maintenance

Error Rate Recoverable Read Error Rate Non-Recoverable Read Error Rate Seek Error Rate	One error per 10^9 bits read One error per 10^{12} bits read One error per 10^6 seek operations
MTBF	15000 power on hours
MTTR	30 minutes
Preventive Maintenance	6000 power on hours or 2 years
Design Life	15000 power on hours or 5 years
Media Life	3.5×10^6 passes/track
CE-Disk	YD-195

Table 2.3 Reliability and Maintenance

Chapter 3. Electrical Interface

The electrical interface of the YD-180 is divided into two categories; Signal Interface and Power Interface. Refer to Fig. 3.3 for all interface connections.

3.1 Signal Interface

All lines in the signal interface are TTL.

3.1.1 Input Lines

There are twelve (12) low active TTL input lines to the YD-180. Ten (10) are standard and two (2) are user installable options. Each line has the following characteristics. Refer to section 3.1.4, Fig. 3.5 for the interface circuits.

High Level	False	2.4V to 5.25V
Low level	True	0V to 0.4V
Input Impedance		150 ohms to 5V

Table 3.1 Input Circuit Electrical Specifications

3.1.1.1 Drive Select 1 – 3

A low active level on this line enables communication between the drive and the drive controller.

Four separate input lines are provided so that a maximum of four drives in a daisy chain can have separate inputs. Traces DS1 to DS4 are provided to select which DRIVE SELECT line will activate the interface signals for a unique drive. Refer to Section 4.1 for additional drive selection methods.

DRIVE NUMBER	DRIVE SELECT input				Traces			
	1	2	3	4	DS1	DS2	DS3	DS4
1	L	H	H	H	S	O	O	O
2	H	L	H	H	O	S	O	O
3	H	H	L	H	O	O	S	O
4	H	H	H	L	O	O	O	S

L = low level
S = short

H = high level
O = open

Table 3.2 Shorting Plugs

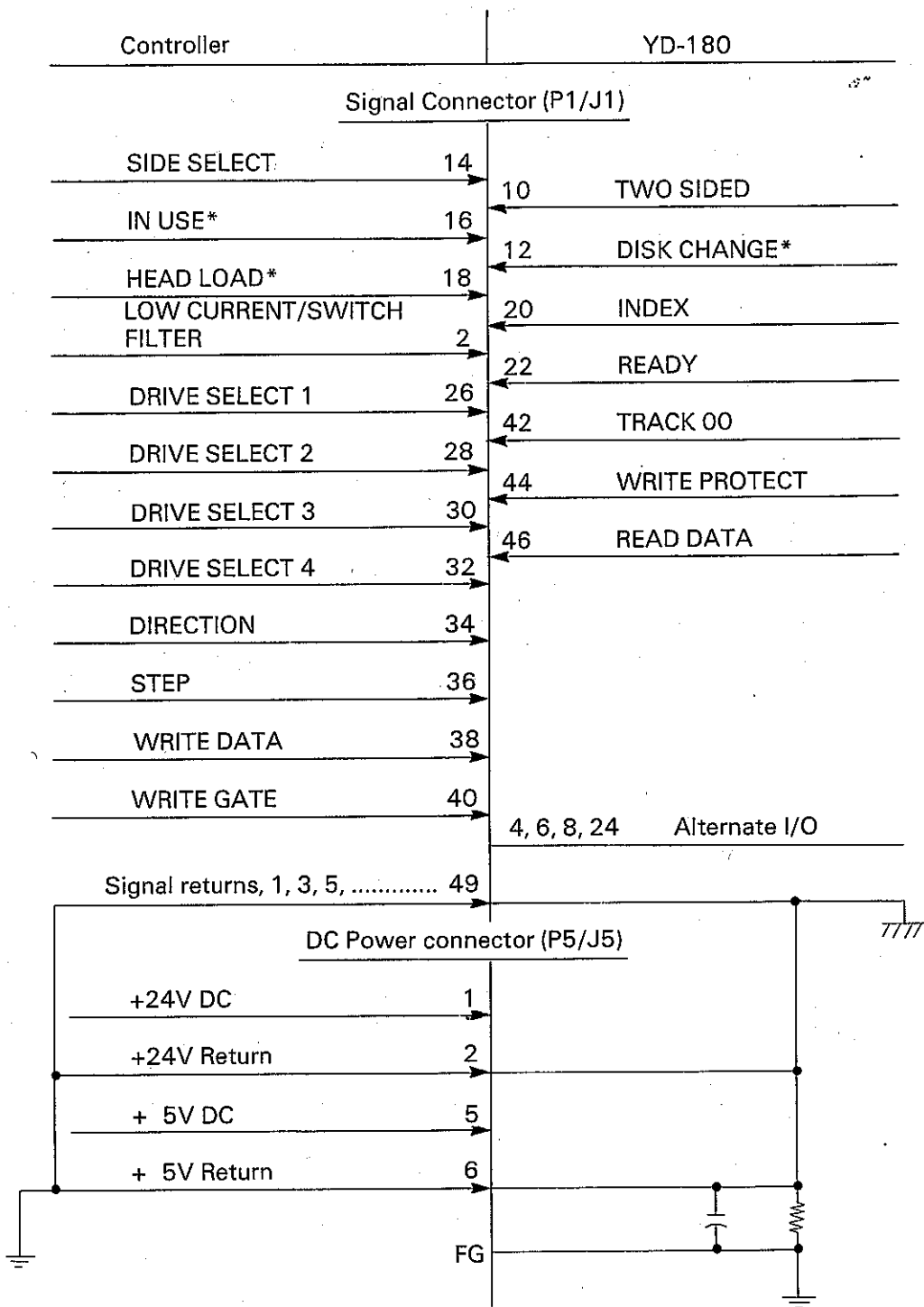

Note
 1. * is optional
 2. Signal Returns (1, 3,, 49), +24V Return, +5V ground and Frame ground must be connected together at the controller.

Fig. 3-3. Interface Connections

3.1.1.2 Direction

This interface signal defines the direction of motion of the R/W head when the STEP line is pulsed. A low level on this line causes the Head Position Mechanism to move the read/write head towards the center of the disk when the STEP line is pulsed. With the Direction line at an high level, a pulse on the STEP line causes the Head Position Mechanism to move the read/write head away from the center of the disk. The state of DIRECTION may not change while STEP is active. Any change on this line must be made at least 1 μ sec before the leading edge of the step pulse. Refer to Fig. 3.10 for timing.

3.1.1.3 Step

A low active level on this line will cause the read/write head to be moved one track. The direction of movement is controlled by the DIRECTION line.

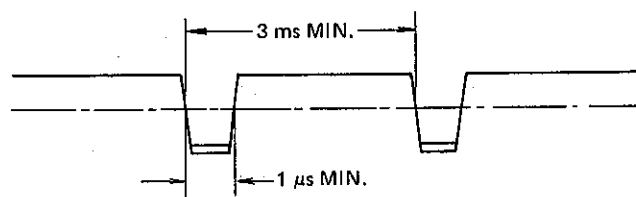

Fig. 3.4 Step

3.1.1.4 Write Data

This interface line provides the data to be written on the disk. Each transition to a low active level on this line causes the write current through the write coils to be reserved.

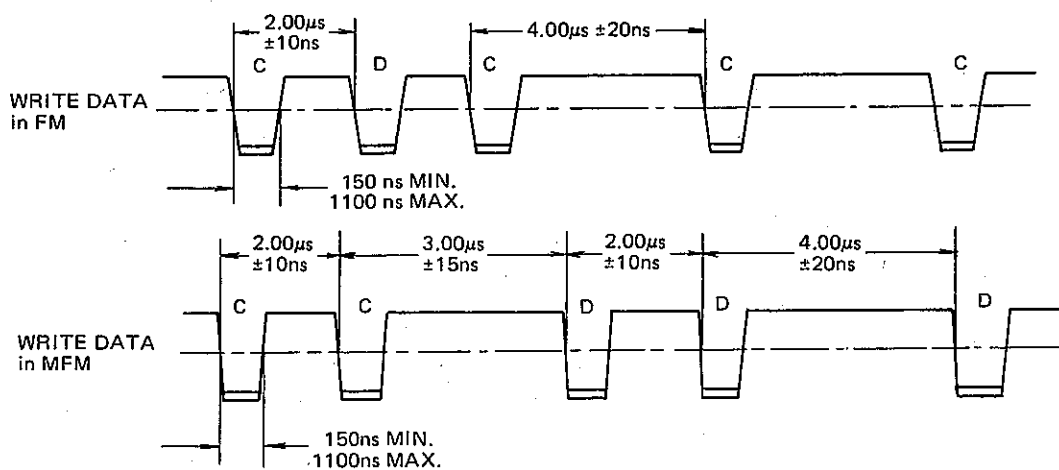

Fig. 3.5 Write Data

3.1.1.5 Write Gate

A low active level on this line enables the write current source, and disables the stepping circuitry. A high inactive level on this line enables the read circuitry.

Deactivation of the DRIVE SELECT, and/or changing the SIDE SELECT must be delayed at least 590 μ s following a write operation to assure that the track is fully tunnel erased.

Refer to Fig. 3.11 and Fig. 3.12 for timing information.

3.1.1.6 Side Select

This interface signal defines which side of a two sided diskette is used for data recording or retrieval. A high level on this line selects the R/W head on the side 0 surface of the disk. A low level on this line selects the R/W head on the side 1 surface of the disk.

When switching between side 0 and 1, a 100 μ s delay is required before any read or write operation can be initiated. Refer to section 4.2 for additional methods.

3.1.1.7 Low Current/Switch Filter

When WRITE GATE is low active, this signal line should be high inactive on tracks 0 through 43, and low active on tracks 44 through 76 (low current). When reading the data, this input should be high inactive on tracks 0 through 59, and low active on tracks 60 through 76 in order to improve the head read output resolution on the inner tracks (switch filter).

3.1.1.8 Head Load (Alternate input)

A low active level on this option input, when READY is active, causes R/W head to be loaded against the diskette.

Refer to section 4.1 for uses and method of installation.

3.1.1.9 In Use (Alternate input)

Refer to Section 4.5.

3.1.2 Output Lines

There are seven (7) output lines from the YD-180, five (5) are standard and two (2) are optional. Each line has three following characteristics.

Refer to Fig. 3.9 for the interface circuits.

High level	False	MAX cutoff current 250 μ A
Low level	True	0 to 0.4V. Max. sink 48 mA

Table 3.6 Output Circuit Electrical Specifications

3.1.2.1 Index

This interface signal is provided by the drive once each revolution. The leading edge of INDEX pulse indicates the beginning of the track.

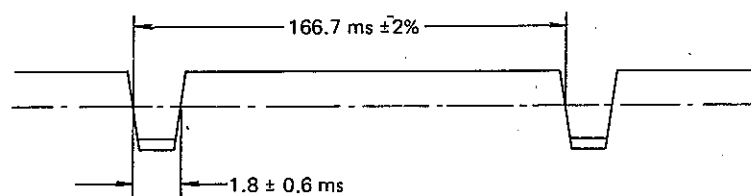

Fig. 3.7 Index

3.1.2.2 Ready

A low active level on this line indicates that two index holes have been sensed after properly inserting a diskette and closing the door, or that two index holes have been sensed following application of +5V to the drive. Refer to section 4.3 for additional methods of using the READY line.

3.1.2.3 Track 00

A low active level on this line indicates that the R/W head is positioned at track 00.

3.1.2.4 Write Protect

A low active level on this line indicates that a diskette with an ISO write protect notch is loaded. Under normal operation, the drive will inhibit writing with a protected diskette installed in addition to notifying the interface.

Refer to section 4.6 for other usages of WRITE PROTECT.

3.1.2.5 Read Data

Data is output to the host system in the same form as write data from the host system. Each flux reversal sensed on the storage element will result in a transition to low active level on this line.

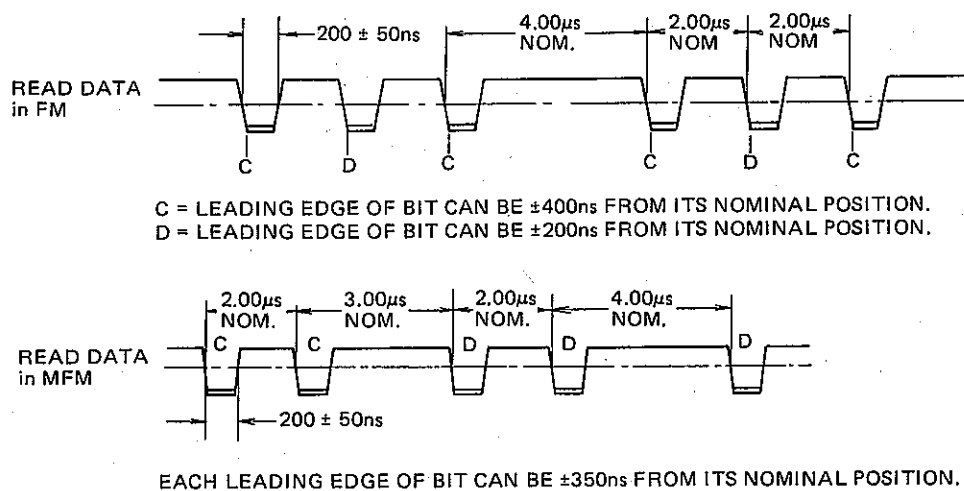

Fig. 3.8 Read Data

3.1.2.6 Disk Change (Alternate output)

Refer to 4.7.

3.1.2.7 Two Sided (Alternate output)

Refer to 4.8

3.1.3 Alternate I/O Pins

Eight (8) alternate I/O pins are provided for alternate control signal interface pins. Each alternate I/O pin has a pad provided for customer installable jumpers. (Pins 4, 6, 8, 10, 12, 16, 18, 24)

Two (2) optional output line and two input lines are connected through normally open traces to four interface lines (pins 10, 12, 16, 18)

3.1.4 Interface Circuits

YD-180 uses the 7438 driver as a line driver and TTL or equivalent gate a line receiver. The input of each receiver is terminated in 150 ohms to +5V.

Refer to Fig. 3.9 for the recommended interface circuits of the controller.

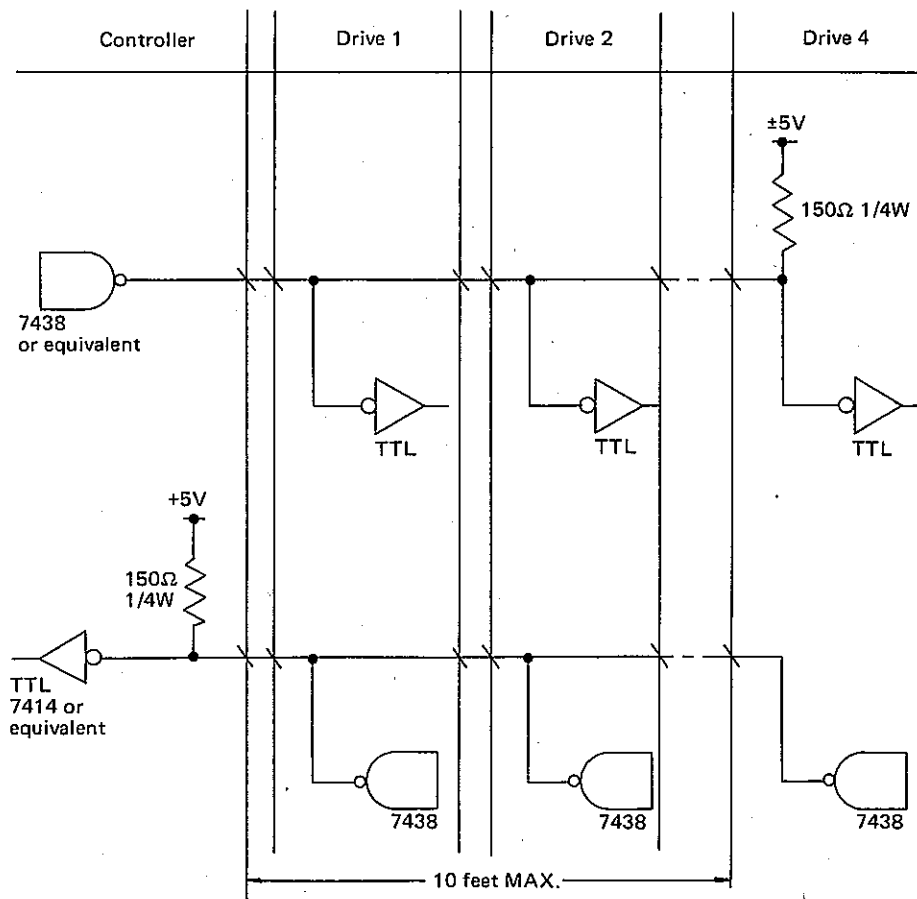

Fig. 3.9 Signal Interface Circuits

3.1.5 Timing

3.1.5.1 Track Access Timing

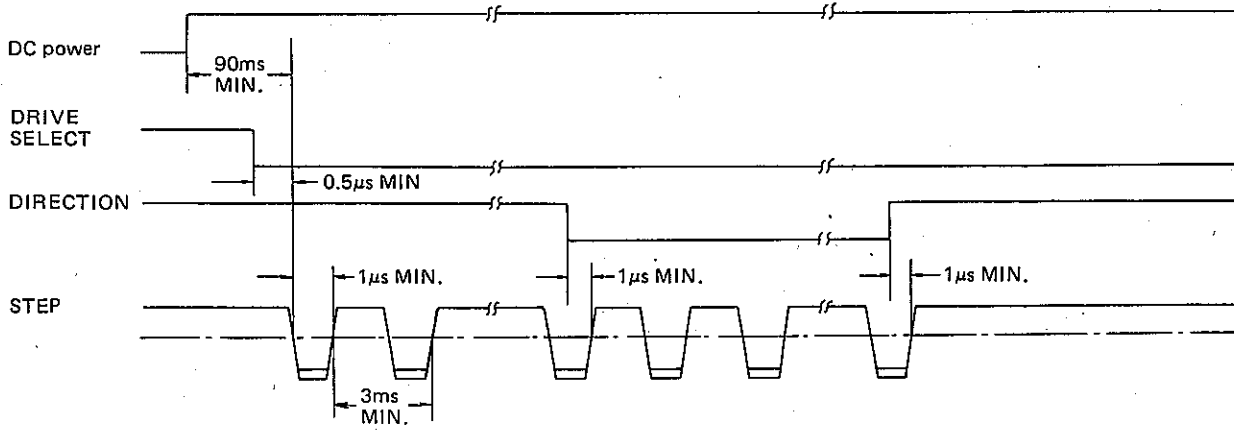

Fig. 3.10 Track Access Timing

3.1.5.2 Read Timing

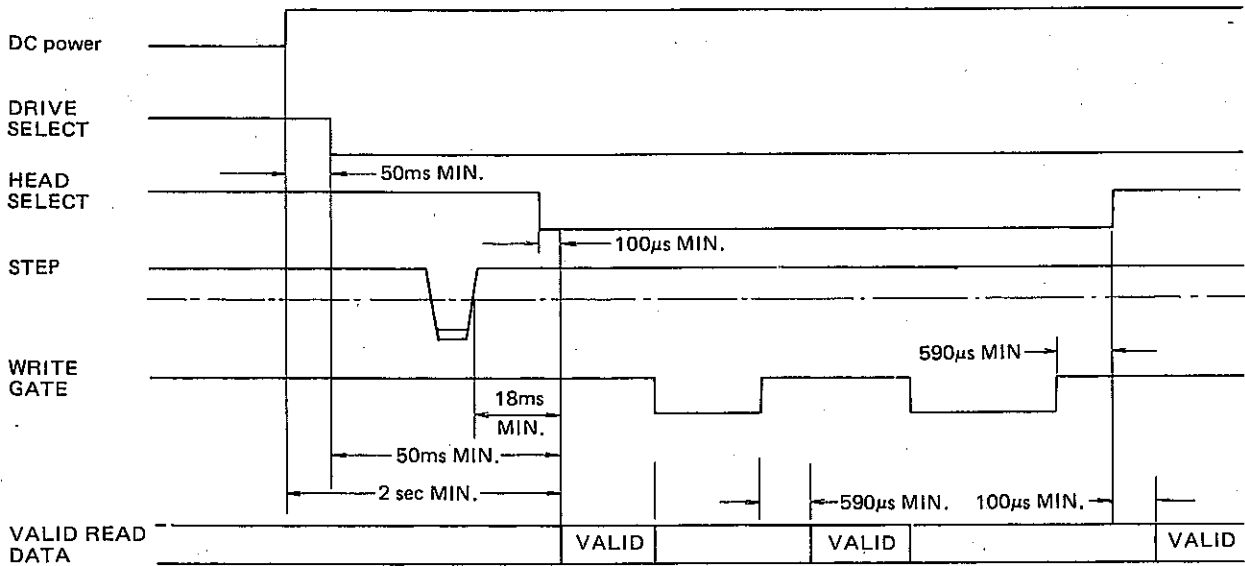

Fig. 3.11 Read Timing

3.1.5.3 Write Timing

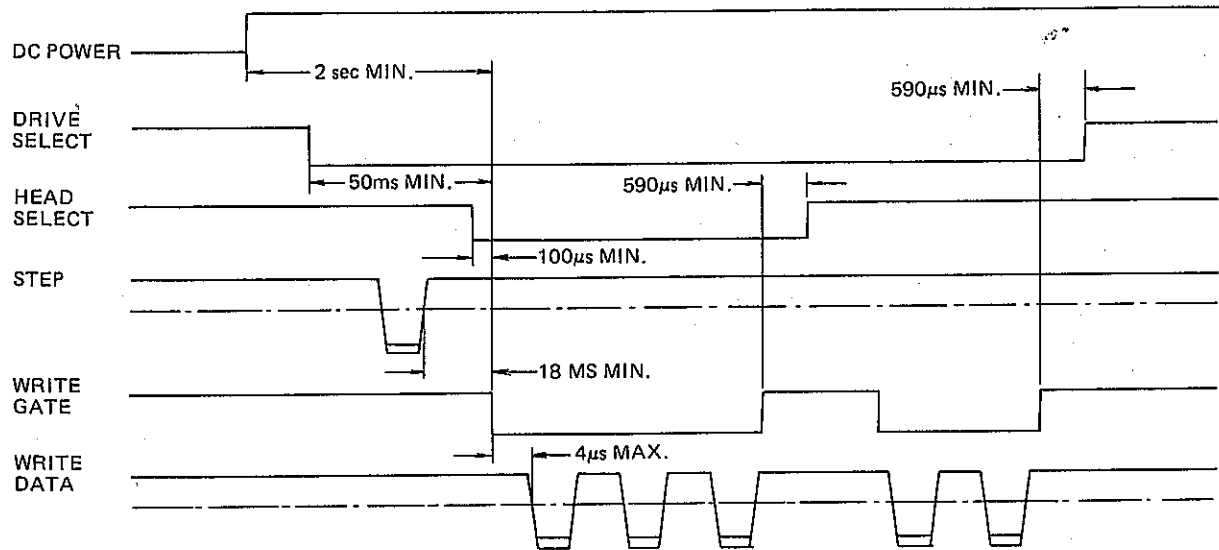

Fig. 3-12 Write Timing

3.2 Power Interface

3.2.1 Power Specifications

Item	DC +24V	DC +5V
Voltage	DC +24V \pm 10%	DC +5V \pm 5%
Ripple Voltage (Including spike noise)	200mVpp Max.	100mVpp
Operating Current Consumption Normal Operation Standard (2) Maximum (3)	0.4A 0.65A Max.	0.4A 0.55A Max.
Motor Start	1.0A Max.	0.5A Max.
Standby Current Consumption (Motor not running) Standard Maximum	0.07A 0.1A Max.	0.38A 0.5A Max.
Power Consumption Operating Standby		10.4W 3.6W

Table 3.18 Power Specifications

Notes:

- 1) Standard Conditions are: 24V, 5V; Normal Temperature; Motor running; Heads loaded.
- 2) Maximum Conditions are: Writing with 24V +10%, 5V +5%, Temperature 5°C; Motor running; Heads loaded.

Chapter 4. Customer Installable Options

The YD-180 can be modified by the user to function differently from the description in section 3. These modifications can be implemented by adding or deleting traces and by use of the Alternate I/O pins. Table 4.2 shows the trace option status as shipped from the factory.

A 12 pin DIP switch is provided for the six most commonly used switch turn options. All these switches are usually shipped as switched on from the factory. See Table 4.1.

Trace	Function - Normally shorted	Function - open
A	(DS) = DS	(DS) = DS * HL
B	(DS) = DS	(DS) = DS, (HL) = HL
X	(HL) = DS	(HL) = DS * HL
Z	(IN USE) = DS	(IN USE) = HL + IN USE
R	READY for multiplex mode	READY for radial mode
I	INDEX for multiplex mode	INDEX for radial mode

Table 4.1 Functions

Note:

DS = DRIVE SELECT, HL = HEAD LOAD

* = AND logic function, + = OR logic function

() means the drive internal logic.

Refer to sections 4.1, 4.3, 4.4, 4.5.

Trace designator	Description	Shipped from factory	
		Open	Short
DS1 ~ DS4	Drive address select pins (up to 4 drives)	DS2, DS3 DS4 are unplugged	DS1 is unplugged
A, B, X	Radial HEAD LOAD		Plugged
Z	IN USE from DRIVE SELECT		Plugged
R	READY alternate output pad		Plugged
I	INDEX		Plugged
C	Alternate input HEAD LOAD	Unplugged	
D	Alternate input IN USE	Unplugged	
DC	Alternate output DISK CHANGE	Unplugged	
2S	Alternate output TWO SIDED	Unplugged	
Y	IN USE from HEAD LOAD	Unplugged	
DL	Door lock latch	Unplugged	
RR	Radial READY		Short
RI	Radial INDEX		Short
WP	Inhibit write when WRITE PROTECT		Short
NP	Allow write when WRITE PROTECT	Pad	
B1 to B4	Two, double sided drive select	Pad	
S1 to S3	Head select option	S1, S3 is pad	S2 is short
4, 6, 8, 10, 12, 16, 18, 24	Alternate I/O pins	Pad	
SF	SWITCH FILTER	Unplugged	
MM0 to MM3	Motor ON/OFF Mode select pins	MM1 ~ MM3 are un- plugged	MM0 is plugged
MD	Motor off delay		Short

Table 4.2 Customer Trace Options

4.1 Head Load Options

Normally, when a drive is selected, its head is loaded and stepper power is changed to +24V.

- Option 1. Allows a drive to be selected without loading the heads or enabling the stepper. The advantage of this option is that the output signals can be monitored with the head unloaded, thereby extending the media life.
- Option 2. Allows a drive to be selected and the stepper to be enabled without loading the heads. Under this option initial recalibration at power on can be performed with the drive not READY.
- Option 3. (Radial READY) allows the drive heads to be loaded without selecting the drive or enabling the stepper. The advantage of this option is that the head can be kept loaded on all drives in order to eliminate head load time when operating disk copy.

Refer to Table 4.3.

Logic	Normal	Option 1	Option 2	Option 3
DRIVE SELECT (DS)	(DS) = DS	(DS) = DS	(DS) = DS	(DS) = DS * HL
HEAD LOAD (HL)	(HL) = DS * R	(HL) = HL * DS * R	(HL) = HL * R	(HL) = HL * R
Installation	on A, B, X unplug C	off X plug C	off B plug C	off A plug C

R = READY, () means drive internal logic, * = AND logic function

Table 4.3 Drive Select/Headload Option

4.2 Side Select Options

Normally, a side is selected from the interface line in a daisy chain system of up to four drives.

4.2.1 Side Select from Direction Line

This option allows both SIDE SELECT and DIRECTION to be multiplexed on the same DIRECTION line.

1. Cut trace S2, and jumper the trace S1.

4.2.2 Side Select for Up to Two Double Sided Drives

This option uses the existing DRIVE SELECT lines to address up to two double sided drives.

1. Cut trace S2, and jumper the trace S3.

DRIVE NUMBER	SIDE SELECT	DRIVE SELECT input				Traces
		1	2	3	4	
1	0	L	H	H	H	Plug DS1 Jumper 2B
1	1	H	L	H	H	
2	0	H	H	L	H	Plug DS3 Jumper 4B
2	1	H	H	H	L	

L: Low level, H: High level

Table 4.4 Side Select for Two Double Sided Drives

4.3 Radial Ready Options

Normally, the READY line from a drive is only available to the interface when it is selected. This option enables the user to monitor the READY line of each drive on the interface all at times.

1. Cut Trace RR
2. Turn off trace R and jumper the pad R to one of the Alternate I/O pins.

4.4 Radial Index Options

Normally, the INDEX line from a drive is only available to the interface when it is selected.
This option enables the user to monitor the INDEX line of each drive on the interface at all times.

1. Cut Trace RI
2. Turn off trace I and jumper pad I to one of the Alternate I/O pins

4.5 In Use Options

Normally, the activity LED is turned on when DRIVE SELECT becomes active.
The door lock is activated when DRIVE SELECT and READY are active.

4.5.1 In Use LED

This optional input, when activated to Low level, turns on the In Use LED.
For uses and procedure, refer to the Table below.

Logic	Option 1	Option 2	Option 3
IN USE	$(\text{IN USE}) = \text{IN USE} + \text{DS}$	$(\text{IN USE}) = \text{IN USE} + \text{HL}$	$(\text{IN USE}) = (\text{IN USE})$
Installation	Plug D Plug Z Unplug Y	Plug D Off Z Plug Y	Plug D Off Z Unplug Y

Note: Do not plug Z and B at same time.
+= OR logic function

Table 4.5 In Use LED

4.5.2 Door Lock Latch Option

With this option, the installed door lock actuator may be latched without maintaining the active status of IN USE input while the door is locked because the IN USE input may be strobed by DRIVE SELECT.

1. Plug trace D
2. Plug trace DL

4.6 Write Protect Option

With this option installed, a Write Protected diskette will not inhibit writing but will be reported to the controller.

1. Cut trace WP and Jumper trace NP.

4.7 Disk Change (Alternate Output)

A low active level on this line indicates that first the DRIVE SELECT signal and then the READY signal have gone false. The disk change circuit is reset to false on the true to false transition of DRIVE SELECT, providing that the drive is READY. See Fig. 4.6.

Notice. Disk change is ANSI mode, different from IBM mode.

1. Plug DC

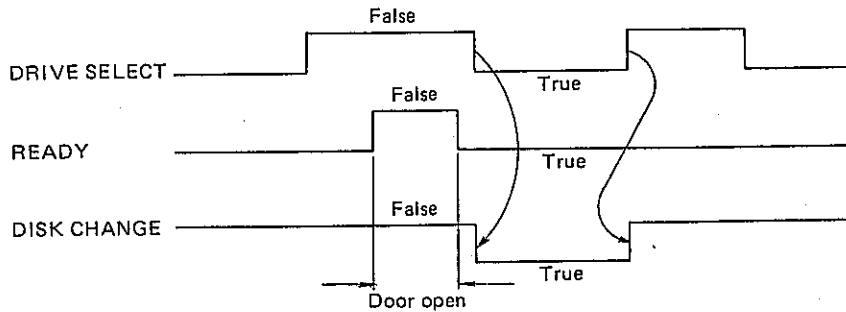

Fig. 4.6 In Use Timing

?
right?

4.8 Two Sided

A low level on this line indicates that a two-sided diskette is rotating, and a high level indicates that a single-sided diskette is rotating.

1. Plug trace 2S

4.9 Switch Filter

With this option as shipped, Pin 2 on the interface accepts a SWITCH FILTER signal during READ operation. Unplugging this option disables the SWITCH FILTER and makes the YD-180 compatible with the YD-174, not the YD-174D.

4.10 MOTOR ON/OFF Option

- MOTOR OFF occurs when there is no media in the drive.
- When media is inserted and the front door closed, MOTOR ON is effective and Internal READY is ON. Motor revolution continues when MOTOR ON is in effect, and stops 2.5 seconds after MOTOR OFF.

(1) Options with Internal signals

	Standard	Option 1	Option 2	Option 3
Motor on Logic	Always ON	DS	DS*HL	HL
Installation	Plug MM0	Plug MM1	Plug MM2	Plug MM3

Table 4.7 Internal Signal Option

- Delay Time Option at MOTOR OFF

MD Short (Standard)	2.5S Delay
MD Open	No Delay

Table 4.8 Delay Time Option

(2) Options with Interface Input

When using the interface option, the signal operates as a MOTOR OFF signal at Low Active. To enable the lines, MC1 to MC4 should be shorted. When using as a MOTOR ON signal, short MC1 to MC4 and half of the M2 pads.

Alternate I/O J1-6	MC1
Alternate I/O J1-6	MC2
Alternate I/O J1-8	MC3
Alternate I/O J1-24	MC4

MC should be shorted in any case

Table. 4.9 Options with Interface Input

In this option there is no delay time option at MOTOR OFF.

Chapter 5. Physical Interface

The interface between YD-180 and the host system is via two (2) connectors: signal (P1/J1) and DC power (P5/J5). Refer to Fig. 5.1 for the interface connection.

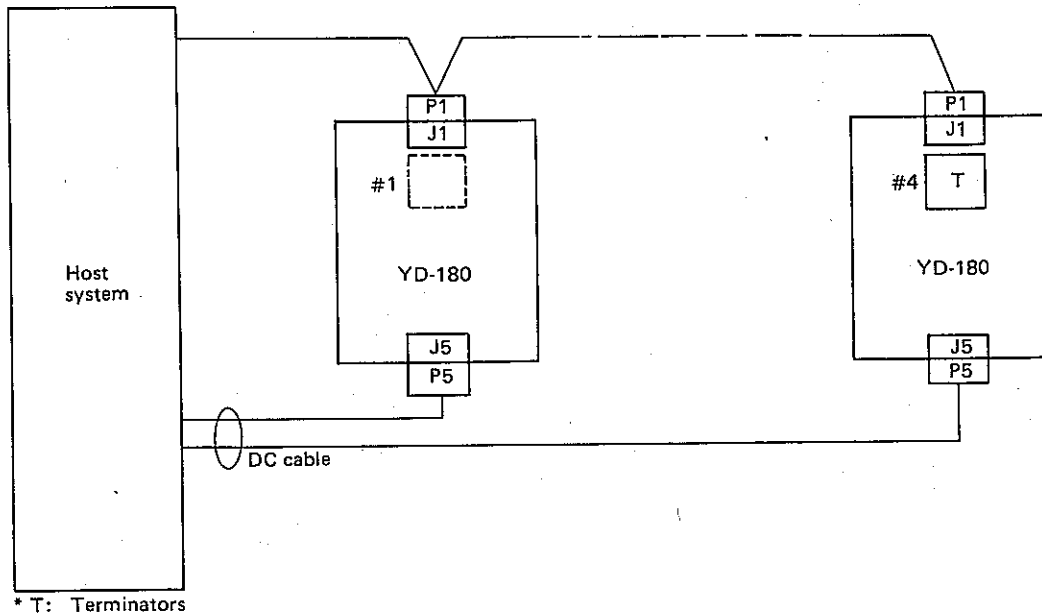

Fig. 5.1 Interface Connection

5.1 Connectors and Cables

5.1.1 Signal Connectors and Cables (P1/J1)

5.1.1.1 Connector J1

Connection to J1 is through a 50 pin PWB edge card connector. The dimensions for this connector are shown in Fig. 5.2.

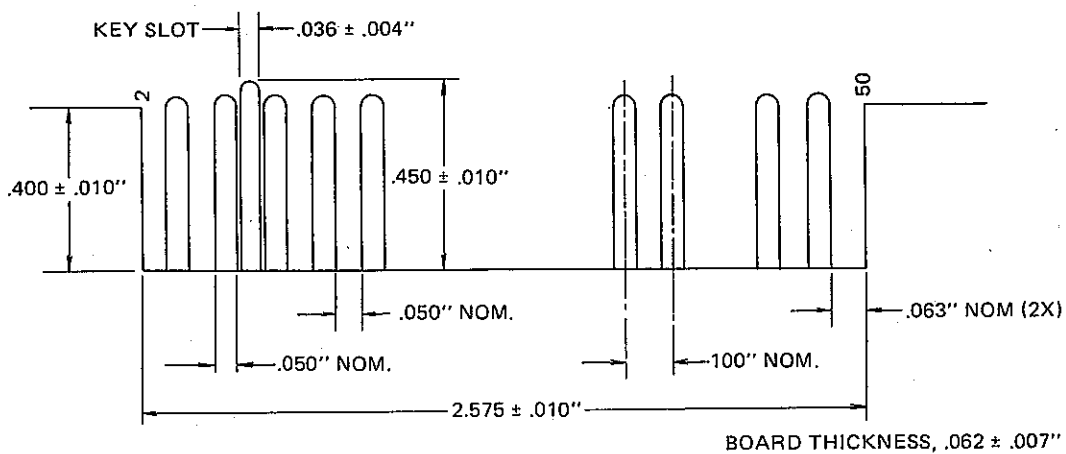

Fig. 5.2 J1 Connector Dimensions (Component Side)

5.1.1.2 Connector P1 for a Flat Cable

Parts		3M P/N
Connector		3415-0001
Polarizing key		3439-0000
	Press	3640
Crimp tool	Locator plate	3443-11
	Platen	3442-1
Flatcable (10 feet MAX.)		3365/50

Table 5.3 Connector P1 for a Flat Cable

5.1.1.3 Connector P1 for A Twisted Pair

Parts	Crimp type	Solder type	
	AMP P/N	AMP P/N	VIKING P/N
Housing	1-583717-1	1-583717-1	3VH25/1JN-5
Contact	583616-5	583854-3	—
Polarizing	583274-1	583274-1	091-0071-000
Crimp tool	90268-1	—	—
Extractor tool	91073-1	91073-1	—
Twist pair (20 feet MAX.)	AWG 26	AWG 26	AWG 26

Table 5.4 Connector P1 for a Twisted Pair

5.1.2 DC Power Connector and Cable (P5/J5)

Parts	P5 (Cable side)	J5 (Drive side)
	AMP P/N	AMP P/N
Housing	1-480270-0	1-380999-0
Contact (6 pins)	60619-1	—
Crimp tool	90124-2	—
Extractor tool	1-305183-2	—
Cable (10 feet MAX.)	AWG 18 to 16	—

Table 5.5 DC Power Connector and Cable

5.2 Connector Pin Assignments

5.2.1 Signal Connector Pin Assignments

See Table 5.6

Signal return Pin No.	Signal Pin No.	SIGNAL NAME	
		STANDARD	OPTION
1 ×	2 ×	LOW CURRENT/ SWITCH FILTER	LOW CURRENT √
3, 5, 7 ×	4, 6, 8 ×	Alternate I/O	
9 cut	10 cut	Alternate I/O	TWO SIDED √
11 ×	12 ×	Alternate I/O	DISK CHANGE √
13 31	14 32	SIDE SELECT √	Alternate I/O
15	16 ×	Alternate I/O	IN USE √
17	18 ×	Alternate I/O	HEAD LOAD √
19	20 8	INDEX	
21	22 34	READY	
23	24 /	Alternate I/O	
25	26 10	DRIVE SELECT 1	
27	28 12	DRIVE SELECT 2	
29	30 14	DRIVE SELECT 3	
31	32 6	DRIVE SELECT 4	
33	34 18	DIRECTION	
35	36 20	STEP	
37	38 22	WRITE DATA	
39	40 24	WRITE GATE	
41	42 26	TRACK 00	
43	44 28	WRITE PROTECT	
45	46 30	READ DATA	
47	48 /	Reserved	
49	50 /	Reserved	

Table 5.6 Signal Connector Pin Assignments

5.2.2 DC Connector Pin Assignment

Pin No.	Signal Name
1	+24V DC
2	+24V RETURN
3	Reserved
4	Reserved
5	+5V DC
6	+5V GND

Table 5.7 DC Connector Pin Assignment

MMZ = MOTOR ON = +5V HL

5.3 Terminators

All signal inputs are terminated in a switch terminator (150 Ohm resistor pack). The switches are in ON position with all terminators connected when the drive is shipped. Before use, make sure that all the drives in the chain are turned OFF except for the last drive, which should remain ON. Refer to Fig. 5.1.

Chapter 6. Mounting

6.1 Drive Mechanical Dimensions

For the dimensions of the YD-180 refer to Fig. 6.1.

6.2 Mounting Recommendations

The YD-180 is designed so that it may be mounted in any plane (horizontal front load vertical front load, vertical top load).

Note: When mounting in horizontal front load position, install YD-180 so that the button on the front bezel is below the front door.

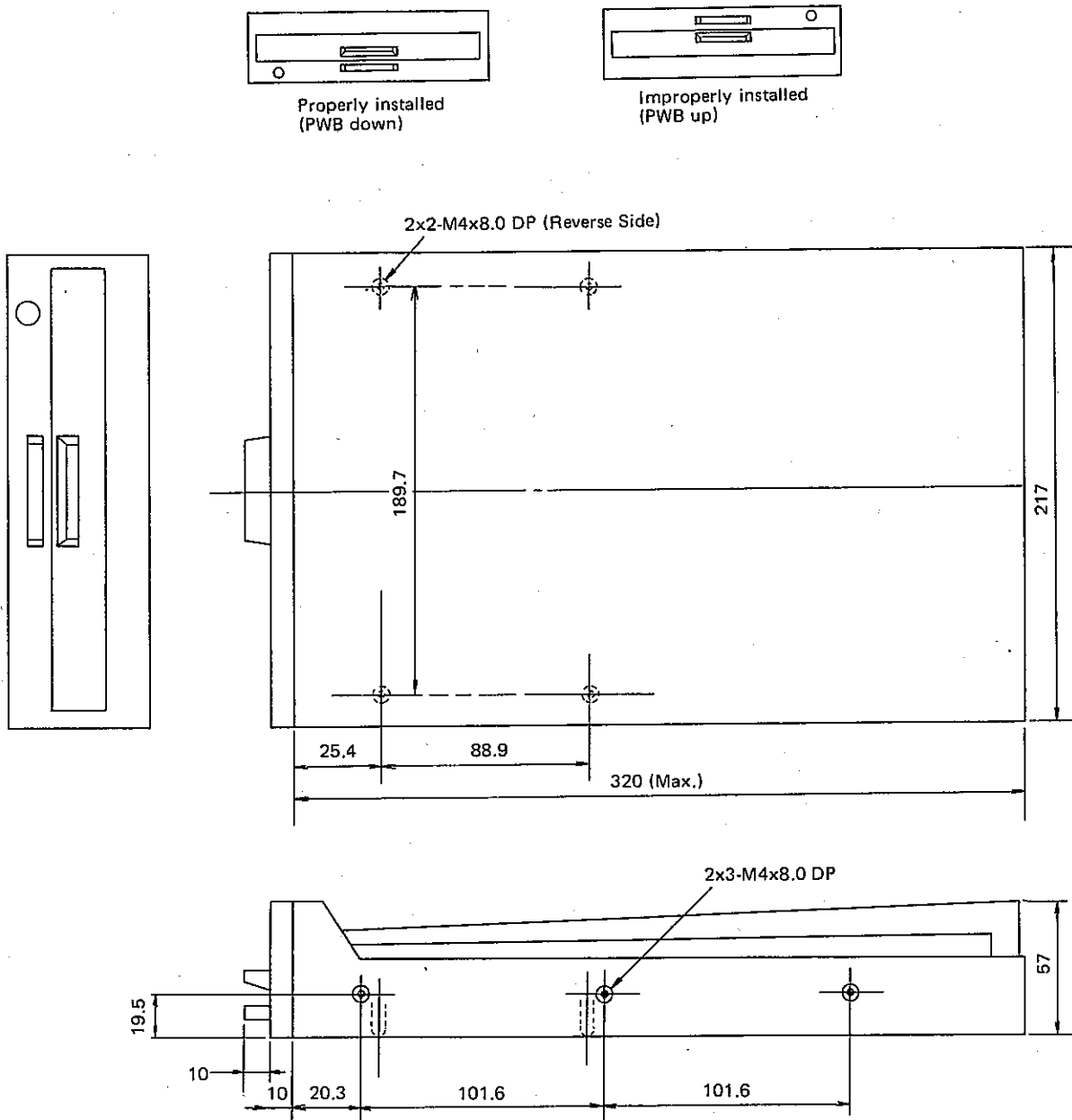

Fig. 6.1 Mounting Dimensions

Chapter 7. IBM Compatibility

The Model YD-180 is designed to employ an IBM or equivalent diskette as recording media.

The YD-180 has the following IBM compatible physical and electrical characteristics.

7.1 Track Positioning

The Diskette Drive positions the R/W head on the center line of track 40 whose relative locations are specified in IBM's Drawing GA21-9388-0 within ± 0.04 mm (± 0.0016 of an inch).

The track 40 track positioning accuracy can be checked with the YD-195 model CE disk.

7.2 Read/Write/Erase Head

The geometry and configuration of the Read/Write/Erase head employed in the diskette drive are equivalent to those of the IBM head.

7.3 Read Output Level

The read output level measured by the following procedure shall satisfy the table below.

- (1) Data is written on standard media with the YD-180.
- (2) The read output level from the standard media above is checked between Test points TP1A and TP1B with the same drive.

TA1A and TP1B are outputs from the head preamplifier.

Track	Output (all "1")	Resolution = $\frac{\text{all "1" output}}{\text{all "0" output}} \times 100$
76	150 mV p-p MIN.	50% MIN.

Table 7.1 Read Output Level

7.4 Write Current

IBM compatibility requires a 20% reduction in write current on tracks 44 through 76.

7.5 Switch Filter

IBM compatibility requires an increase in read output resolution on tracks 60 through 76.

7.6 Index Positioning

The diskette drive Index Sensor adjustment allows precise positioning of the Index Sensor with relation to the R/W head gap.

The positional difference of the Model YD-180 shall be within ± 500 μ s, verifiable with the YD-195 CE Disk.

Chapter 8. Double Density Recording

There are two different methods of double density recording, IBM Diskette 2D compatible or non IBM compatible. Refer to the following table.

	IBM Diskette 2D compatible	Non IBM compatible
Recording Method	MFM	MFM
Write mode (1) Write Precompensation	Without precompensation	With write precompensation of 0 ms on Tracks 0 – 43 250 ms on Tracks 44 – 76
(2) Low current Low current/ Switch filter Input	High inactive on Tracks 0 – 43 Low active on Tracks 44 – 76	High inactive on Tracks 0 – 43 Low active on Tracks 44 – 76
Read mode Low current/Switch filter Input	With post compensation High inactive on Tracks 0 – 59 Low active on Tracks 60 – 76	Without post compensation High inactive on Tracks 0 – 76

Table 8.1 Double Density Recording

Y-E DATA Inc.

Sunshine 60 P.O. Box 1171
3-1-1 Higashi-Ikebukuro
Toshima-ku, Tokyo 170, Japan
Tel: Tokyo (03) 989-8001
Telex: 272-3266 YEDATA J
Fax: (03) 989-8008

Printed in Japan © 300
